

# Extended Relativity —Exploiting the Loopholes in Einstein's Relativity

(2010 rev2012-01)

Conrad Ranzan

DSSU Research, Niagara Falls, Canada L2E 4J8

Email: Ranzan@CellularUniverse.org

Preprint of an article submitted for consideration in **Physics Essays** Journal © 2012 copyright PEP

**Abstract:** Several loopholes in the logic structure of Einstein's special relativity (ESR) are detailed. The exploitation of the loopholes leads to what is being called Extended relativity (also referred to as DSSU\* extended relativity). The Extended Lorentz transformations are presented; as well as the Extended relativity equations for time, length, momentum, mass, and kinetic energy. The optical interferometer experiments of Michelson & Morley and of Miller are analyzed and discussed. The significance of the difference between the vacuum-mode and gas-mode interferometer experiments is emphasized. While one experiment mode is consistent with a key hypothesis of Einstein; the other mode exposes a serious flaw. The repeated discovery of light-speed anisotropy, also referred to as the detection of absolute motion, exposes the inadequacy and incompleteness of the Einstein postulates. Essentially, the present Paper charts a course by which relativity theory can be made more inclusive and conform to the existence and detectability of 'absolute' motion.

**Keywords:** Special relativity; DSSU\* extended relativity; relative motion; absolute motion; preferred frame; aether-space; Lorentz transformation; Dayton Miller; lightspeed anisotropy; Michelson-Morley.

\* DSSU is the acronym for the Dynamic Steady State Universe —the cosmology theory that holds that aether-space is dynamic and that aether-space expands and contracts *regionally and equally* resulting in a cosmic-scale cellularly-structured universe. It is a model based on the premise that all things are processes.

## Introduction

Let me place the substance of this article into historical perspective. After Albert Einstein formulated his theory of special relativity in 1905 there developed an intense rivalry-of-ideas between Einstein and Dayton Miller. Einstein, the relativist, was committed to a theory that proclaimed (implicitly) that aether does not exist; while Miller was equally committed to proving that aether *does* exist. The rivalry continued until Miller's death in 1941. By then, Miller had amassed a vast amount of irrefutable evidence that aether, and relative motion with respect to aether, *does* exist. Miller was gone but his evidence survived. Given that Miller's aether-evidence undermines the foundation of relativity theory, it would not be an exaggeration to say that Einstein feared *that* evidence. Einstein feared the discovery of aether.<sup>1</sup>

## 1 Aether Feared versus Aether Discovered

Einstein on several occasions expressed his grave concerns over the possible discovery of aether. The following quote is one of the clearest expressions of his concern:

*My opinion about Miller's [aether] experiments is the following. ... Should the positive result be confirmed, then the special theory of relativity and with it the general theory of relativity, in its current form, would be invalid.* Experimentum summus judex. — Einstein in a letter, July 1925, to Edwin E. Slosson<sup>2</sup>

Keep in mind that by 1915 Einstein had constructed two relativity theories in which space was a geometric field (in 1915 it became a *geometrodynamical* field); in these theories *space* was *not* an aether medium. Not surprisingly, Einstein remained deeply apprehensive for the rest of his life. In 1954, in a

letter to his life-long friend Besso, Einstein wrote:

*I consider it quite possible that physics cannot be based on the field concept, i. e., on continuous structures. In that case nothing remains of my entire castle in the air, gravitation theory included, [and of] the rest of modern physics.*<sup>3</sup>

Einstein (and Besso) died the following year.

What he feared was the detection of **the classical aether**. Einstein probably suspected that Miller may have ‘discovered’ the traditional aether (or even the Lorentz’s static-aether —the light conducting medium used in Hendrix Lorentz’s “Theory of Electrons,” which theory was the final point in the development of the classical aether theories at the end of the 19<sup>th</sup> century). In 1933 Miller’s definitive study was published. Given that his great theory was in jeopardy, Einstein would surely have given Miller’s paper, titled *The Ether-Drift Experiment and the Determination of the Absolute Motion of the Earth*, a thorough read. He would have concluded that ‘something’ was discovered. And Einstein was certainly familiar with the classical aether.

But *that* is not what was discovered. *What Miller and others detected, without fully realizing it, was a dynamic (and nonmaterial) aether* —not the traditional static aether.

What Einstein feared was the aether of column 2 in the table (below). But what Miller actually found was the radically different aether of column 3.

**Table I**

Two Types of Aether-Space Compared		
Property	Aether Feared (traditional material aether)	Aether Discovered (nonmaterial DSSU aether)
A Medium that:	“Fills all space”	“Fills all space”
LUMINIFEROUS	Yes	Yes
SPEED OF LIGHT (in vacuum) Light source at-rest wrt aether. Observer moving wrt aether.	$v_{\text{light}} \neq c$ <b>Historians tell us this is the reason the traditional aether failed</b>	$v_{\text{light}} = c$ [*] <b>Consistent with Einstein’s own theory</b>
SPEED OF LIGHT (in vacuum) Light source moving wrt aether. Observer at-rest wrt aether.	$v_{\text{light}} = c$	$v_{\text{light}} = c$
DYNAMIC or GRAVITATIONAL	No	<b>Yes</b>

\* The proof of this is presented in the article: C. Ranzan, *Resolving a Paradox in Special Relativity --Absolute Motion and the Unified Doppler Equation* (Physics Essays Vol 23, 2010 Dec)

The former would have, without any doubt, caused “...the whole relativity theory [to] collapse ... like a house of cards.” But not so the latter.

It is because the aether that was actually discovered has a dual nature (which notably includes *apparent* relativistic effects) that Einstein’s special relativity (ESR) did not collapse. The aether that has been repeatedly detected is the *dynamic nonmaterial aether* (of [column 3](#)) —a medium in which Einstein’s relativity works admirably in *apparent* situations (with no regard to the aether frame) and also allows for *absolute* situations (which *do* give regard to the aether frame) for which Einstein’s relativity, of course, has very little to say. As is well known, aether-referenced motion is outside the scope of ESR.

With the benefit of hindsight we may note with irony, Einstein need not have feared the pending recognition of the discovery of aether-space. In fact, it would have presented his genius-mind with an opportunity to not only broaden and improve special relativity but also to introduce a vital missing component into general relativity —the “missing component” being the causal mechanism of gravity.

It makes for a remarkable footnote in the history of science: Einstein’s fear, and who knows what inward struggle was involved, was unfounded.

Although Einstein focused on the development of his abstract space, no doubt testing different versions leading up to his testable theories (both special and general relativity), it seems never to have occurred to him that there may be a quasi-physical aether other than the classical aether.

## 2 The Loophole in the Logic Structure of Special Relativity

Einstein’s theory is based on two assumptions. They are expressed in the two postulates of the theory:

1. The Relativity Postulate: The laws of physics are the same for observers in all inertial reference frames. There is no preferred frame of reference.

2. The Speed of Light Postulate: The speed of light in vacuum has the same value  $c$  in all directions and in all inertial reference frames. There are also axiomatic considerations (which are discussed in [Section 7](#)).

From these assumptions it was possible to develop the equations that made testable predictions related to clock time, length contraction, and apparent mass variance. For example, on the subject of length contraction Einstein stated “the contraction of moving bodies follows from the two fundamental principles of the theory, without the introduction of [other] hypotheses ...”<sup>4</sup>

Now notice that Einstein framed his theory as an *if-then* argument. He did NOT frame the theory as an *if-and-only-if-then* argument.

Einstein assumed that the speed of light is constant for all relatively moving observers (i.e., with constant motion relative to the light source) and there is no preferred frame (i.e., no aether). Let this compound assumption<sup>A</sup> be represented by “**A**”.

On the basis of this assumption Einstein deduced the ESR formalism leading to: the prediction of several relativistic effects, of which, time dilation has been extensively confirmed; the prediction of the aberration of starlight<sup>5</sup>; and agreement with “all facts of experience which support the electromagnetic theory [of Maxwell and Lorentz].”<sup>6</sup> Let the predicted effects be represented by “**B**”.

If constancy of light speed and absence of aether is assumed then relativistic effects follow. Symbolically, the ESR theory is: If **A** then **B**.

Now, the predictions made by the theory turned out to be true. Observational evidence effectively made **B** true.

Here is where some relativists fall into a logic trap. They will say that since **B** is true, therefore **A** must be true as well. Symbolically, their position is: If **B** then **A**.

The problem in the logic, and the problem for the relativists, is that the truth of **B** *does not* imply the truth of **A**. Claiming “if **B** then **A**” is known as *the fallacy of the converse*.

**Table II**

The Flawed Defense of Einstein’s Relativity		
	Symbolic Argument	Verbal Argument
Einstein’s Assumption:	<b>A</b>	The speed of light is constant for all observers and there is no preferred frame (no aether).
Einstein’s Theory:	If <b>A</b> then <b>B</b>	If assumption is accepted as true then certain relativistic effects follow.
Evidence:	<b>B</b> is true	Relativistic effects are detected and confirmed.*
Conclusion:	If <b>B</b> then <b>A</b>	Therefore, speed of light is constant and there is no preferred frame.
<i>Fallacy:</i>		<i>fallacy of the converse</i>

\* Relativistic mass increase is subject to question.

Fundamental logic shows that the conclusion, as argued in [Table II \(above\)](#), is *not necessarily true*. What this means is that the logic of the argument permits other assumptions. There may be other assumptions that lead to the prediction of **B** —other assumptions that are compatible with the evidence of relativistic effects. One could try using a different assumption —and still stay within the logic of ESR theory.

Based on the non-exclusive if-then presentation of ESR and the truth of the evidence supporting its predictions, I am unequivocally able to assert that the conclusion (in the table [above](#)) need not be true. The assumption that there is *no preferred frame* is not necessarily true. In other words, the assumption

<sup>A</sup> Included in the “**A**” assumption is, of course, the premise that the laws of physics are the same for all observers.

might also be that there *is* a preferred frame and the speed of light appears to be constant for all observers. (Relativistic effects are still predicted since they are embedded in the Lorentz transformations.) It turns out that the new interpretation is superior, as I will show later.

The relativity theory is not based on an exclusive set of assumptions. This is the chink in the ESR armour. The point is, the logic loophole in ESR permits other assumptions. It allows changes to be made to the original assumptions.

### 3 The Loophole in the Application of the Lorentz Transformations (and the Unnecessary Assumption of ESR)

Einstein assumed (as part of Postulate #1) that there was “no preferred frame.” He rejected the notion of a special frame in no uncertain terms: “According to this theory there is no such thing as a ‘specially favoured’ (unique) co-ordinate system to occasion the introduction of the aether-idea, hence there can be no aether-drift, nor any experiment with which to demonstrate it.”<sup>7</sup> (Essentially he defended his position by saying that his theory required it.) But what is it about the theory that demanded “no preferred frame”?

The theory was a codification of Einstein’s vision of an abstract world —a world of non-absolutes, no absolute-rest observer, no absolute frame of reference. Einstein, above all, was a Platonist —he believed that abstract reality was more real than perceived reality. And so, Einstein’s vision was a relativized world. On philosophical grounds the “no preferred frame” makes a fitting assumption for his theory.

But there is another reason. He believed that a preferred frame —a physical aether-like frame— would negate the one essential assumption of his theory. If Einstein were “to occasion the introduction of the aether-idea” then the speed of light would *not* remain invariant for all observers. This was for Einstein and his contemporaries a well grounded concern. It was the reason the 19<sup>th</sup> century aether failed. The choice was either embrace *aether* or *lightspeed invariance*; one or the other, not both. Lightspeed invariance prevailed. And the rest is history as 20<sup>th</sup> century physics became burdened with a restrictive and incomplete theory of space and time.

I should explain, in greater depth, Einstein’s choice. As a bonus, the apprehension, discussed earlier, over the discovery of aether, will become crystal clear.

Actually, there was an additional choice. Near the end of the 19<sup>th</sup> century Lorentz modified the classical aether so that the speed of light *would* remain invariant. Why didn’t Einstein adopt this aether into his relativity theory? He could easily have done so, but he did not. For one thing, Lorentz’s aether was believed to be undetectable! Lorentz himself was convinced it could not be detected. Also, Henri Poincaré, who played a major role in the development of relativity, claimed that *it was impossible to demonstrate absolute motion* (and published his proof in an important work *Sur la dynamique de l’électron* in 1905). Furthermore, there was the evidence: Einstein accepted the dominant view that the Michelson-Morley 1887 experiment “proved” it was not detectable. If the aether is not detectable, then one may as well declare that it does not exist. Einstein did what any avowed Platonist would have done —he simply abolished the undetectable, redundant, aether. But, in doing so, Einstein had set a trap that could potentially ensnare his relativity theory.

Let me be quite specific here. If aether was ever to be discovered by some “future” experiment, then it would not be Lorentz’s aether since *that* aether was supposedly undetectable —per Lorentz’s theory, Poincaré’s proof, and Michelson & Morley’s experiment. Therefore, it would have to be the old classical aether which, by definition, *IS* detectable. Einstein would, undoubtedly, have used this simple logic. This shines a new light on Einstein’s apprehension following his 1905 publication of relativity theory. The aether that that Einstein later “feared” was not Lorentz’s aether —if it did exist it was *not* detectable and *not* a cause for concern. No, the aether that threatened was the old classical aether —for if it did exist *it would be detectable!*

In summary, Einstein knew of Lorentz’s aether and, rather than choosing to incorporate it, felt confident in abolishing it. And so, the choice was made.

The choice was made. Lightspeed invariance prevailed and became enshrined in the 2<sup>nd</sup> Postulate. Why is this so important? ... It is because without this basic feature Einstein could not have used the Lorentz transformation equations. And without the Lorentz transformations . . . well, there would simply be no modern relativity theory.

And a further reason was that Einstein wanted his theory to be consistent with what he believed was experimental evidence supporting his ‘abstract’ assumption.

During the years leading up to the publication of special relativity, Einstein had given careful

consideration to the pivotal 1887 experiment performed by Michelson and Morley. He understood that the experiment was a test for the non-constancy of the speed of light along two identical arms of the apparatus. The results of the test were inconclusive —Michelson even suggested improving and repeating the experiment. Einstein chose to interpret the results as unconditional light speed invariance (ignoring the very real possibility that it may also be interpreted as indicating *conditional light speed invariance* — conditional on the presence of aether and on the measuring method).

Thus Einstein had his abstract space and his lightspeed invariance. He was in a position to exploit the Lorentz transformations, which he did.

Now here is the loophole in the application of the Lorentz transformations: While *lightspeed invariance* is a prerequisite in the transformation operation, the “no preferred frame” is unnecessary. Although Einstein thought it was necessary,<sup>B</sup> it is entirely optional!

The loophole means that the existence of a preferred frame does not preclude the applicability of the Lorentz transformations. The loophole means that frames in aether-space may be subjected to the same transformations (with the proviso). The proviso is, of course, that the speed of light must *appear* constant for all observers using a two-way method to measure it. (More on this later.)

**Table III**

Lorentz Transformation Equations Applicability			
Theory:	ESR	Traditional Aether	<b>Loophole Option</b> (DSSU aether-space)
Type of space:	abstract	static-aether medium that permeates all space	dynamic medium that permeates all space
Prerequisite Test (lightspeed invariance for all inertial observers):	PASS	FAIL	PASS
Preferred frame of reference:	NO	YES	YES
Suitability for transforming coordinates/observations via Lorentz formalism:	YES	NO	<b>YES</b>

The “no preferred frame” is an unnecessary assumption. It is not needed for a functional relativity theory. It will be shown later that the opposite assumption, that there is a preferred frame (an aether frame), is entirely compatible with the Lorentz transformation formalism.

## 4 Exploiting the Loopholes

### 4-1 Exploiting the 1<sup>st</sup> Loophole

As detailed in [section 2](#) above, ESR is structured as a non-exclusive if-then argument. The “if” is, in part, the assumption of *no preferred frame*; the “then” is, collectively, the theory’s predictions. The truth of the evidence supporting the predictions does not, in and of itself, make the assumption true. The assumption that there is *no preferred frame* is not necessarily true. I could, for example, make the assumption this way: The speed of light is constant with respect to aether-space **and** the speed of light for vacuum appears constant for all inertial observers; and simply discard the “no preferred frame” assumption.

And that is exactly what I will do. With the revised assumption, relativistic effects, as pointed out earlier, are still predicted since they are embedded in the Lorentz transformations. Remarkably, by introducing a preferred frame the ‘extended’ theory is able to make more predictions (including verifiable predictions). The framework of the DSSU argument is as shown in [Table IV](#):

<sup>B</sup> Einstein clearly assumed that his postulate has the status of a necessary condition when he wrote:

“Since the special theory of relativity revealed the physical equivalence of all inertial systems, it proved the untenability of the hypothesis of an aether at rest. It was therefore necessary to renounce the idea that the electromagnetic field is to be regarded as a state of a [medium].” — A. Einstein, *Relativity The Special and the General Theory* (Wings Books, New York, 1961) p170

**Table IV**

The Logic Structure of Extended Relativity	
Assumption:	The speed of light in vacuum appears to be constant for all observers <b>and</b> there is a preferred frame.
Theory:	If assumption is assumed true then certain apparent relativistic effects follow — <i>as well as absolute effects</i> .
Evidence of relative motion effects:	Relativistic effects are detected and confirmed.
Evidence of absolute motion effects:	Light speed anisotropy detected. Intrinsic length-contraction detected.

The resulting Extended theory makes for a broader theory since it predicts more than the theory it subsumes. While the Einstein formalism leads to a theory of apparent relative-motion effects, the Extended formalism leads to a theory of apparent *and absolute* effects.

#### 4-2 Exploiting the 2nd Loophole

It is commonly believed that the application of the Lorentz transformation equations precludes all notions of aether. The belief is that the presence of aether will adversely affect the principle of *light speed invariance for all inertial observers*. Although this belief is valid for the traditional aether, it is not necessarily true for all types of aether; recall, the Lorentzian aether has the *invariance*, but does not have detectability, at least not theoretically. The loophole in the application of the Lorentz transformations is that if a defined aether-space has the essential property that all inertial observers *do* measure light speed invariance (using a reflected path in vacuum) then the Lorentz transformations are definitely applicable.

**Table V.** The basic *Lorentz transformations* (middle column) originally applied to Lorentz's own relativity theory in which aether does exist but was believed to be undetectable; they also apply to Einstein's theory in which no aether exists (or is completely ignored). The *Extended transformations* (RH column) apply when aether *is* detectable. And since the Extended equations can be converted to the Basic ones, the Extended transforms can be applied to Lorentz's aether theory, Einstein's abstract theory, and, of course, the Extended theory itself.

Coordinate Systems Conversions		
	Basic Lorentz Transforms (converting coordinates of Frame-S to Frame-S')	Extended Lorentz Transformations (converting coordinates of Frame-S' to Frame-S'')
Perpendicular-to-motion coordinate:	$y' = y$	$y'' = y'$
Perpendicular-to-motion coordinate:	$z' = z$	$z'' = z'$
Axis-of-motion coordinate:	$x' = \gamma(x - vt)$	$x'' = \gamma_A \gamma_B \left[ x' \left( 1 + v_A v_B / c^2 \right) - t' (v_A + v_B) \right]$
Clock time:	$t' = \gamma \left( t - vx/c^2 \right)$	$t'' = \gamma_A \gamma_B \left[ t' \left( 1 + v_A v_B / c^2 \right) - x' (v_A + v_B) / c^2 \right]$
Distance between pair of events:	$\Delta x' = \gamma (\Delta x - v \Delta t)$	$\Delta x'' = \gamma_A \gamma_B \left[ \Delta x' \left( 1 + v_A v_B / c^2 \right) - \Delta t' (v_A + v_B) \right]$
Time interval between pair of events:	$\Delta t' = \gamma \left( \Delta t - v \Delta x / c^2 \right)$	$\Delta t'' = \gamma_A \gamma_B \left[ \Delta t' \left( 1 + v_A v_B / c^2 \right) - \Delta x' (v_A + v_B) / c^2 \right]$
Lorentz factors:	Relative Lorentz factor: $\gamma = \frac{1}{\sqrt{1 - (v/c)^2}}$	Intrinsic (aether-referenced) Lorentz factors: $\gamma_A = \frac{1}{\sqrt{1 - (v_A/c)^2}} \quad \& \quad \gamma_B = \frac{1}{\sqrt{1 - (v_B/c)^2}}$
<p><b>Notes:</b> Un-subscripted velocity magnitudes refer to relative motion; subscripted velocity magnitudes refer to absolute motion with respect to aether-space. The derivation of the Extended Lorentz Transformations is detailed in the Appendix. (Also see C. Ranzan, <i>DSSU Relativity—The Lorentz Transformations Applied to Aether-Space</i>, Physics Essays Vol <b>23</b>, No.3, p520)</p>		

The loophole is this: regardless of any other property which some hypothetical aether may possess, the only essential property is that all observers —no matter what their constant motion through the aether may be— must measure the same two-way speed<sup>c</sup> for any light pulse *in vacuum*. DSSU aether-space

<sup>c</sup> The “two-way speed” refers to the traditional out-and-reflected-back method of timing a light pulse.

does have this property.

How then is the loophole exploited? . . . It is simply a matter of formulating the Lorentz transformations so that velocities are referenced to the preferred frame (aether-space).

Table V above shows both the basic transformation equations and the Extended Transformations. The extended equations are algebraically derived from the basic Lorentz transformations. The notable difference is that column 2 deals with relative velocities, column 3 deals with absolute velocities (i.e., they are referenced to the aether medium, which, in the DSSU theory, is measurable).

The extended Lorentz transformations are then used to derive the equations for DSSU extended relativity. They include expressions for *apparent* -velocity transformation, -time dilation, -length contraction, -momentum, -mass, and -kinetic energy.

Turning now to the evidence of an absolute motion effect.

## 5 How the Extended Theory Explains Results of Historical Experiments (Compared to the Standard Explanation)

### 5-1 The Apparatus of the Michelson & Morley Experiment

In 1887 Albert Michelson and Edward Morley constructed a highly-sensitive version of a light interferometer (an instrument that Michelson had invented some years earlier) to test for the effects of aether motion on the propagation of light within the device. Specifically, the motion of aether passing through the device was expected to alter the path lengths of the light beams and consequently produce an interference pattern in the detector (or viewing screen). The apparatus was designed to measure the difference in the distance (or equivalently the travel time) that light travels through the apparatus in two perpendicular directions —ideally, one in the direction of the aether flow and the other across the direction of flow. Fig. 1 shows the basic arrangement of the apparatus. The light source, mirrors, and detector were mounted on a massive stone slab (about 1 meter square) that was suspended on a pool of mercury so that the slab could be rotated smoothly about a vertical axis. Through the use of additional mirrors, not shown in the figure, the length of each 'arm' was increased to 11 meters. The path-length difference that was sought would be revealed in the shift of the interference pattern of the recombined beams converging on the detector. Michelson and Morley monitored the interference pattern as they rotated the slab and could thereby determine the maximum interference fringe-shift which in turn allowed them to calculate the maximum path length difference (or time-of-travel difference).

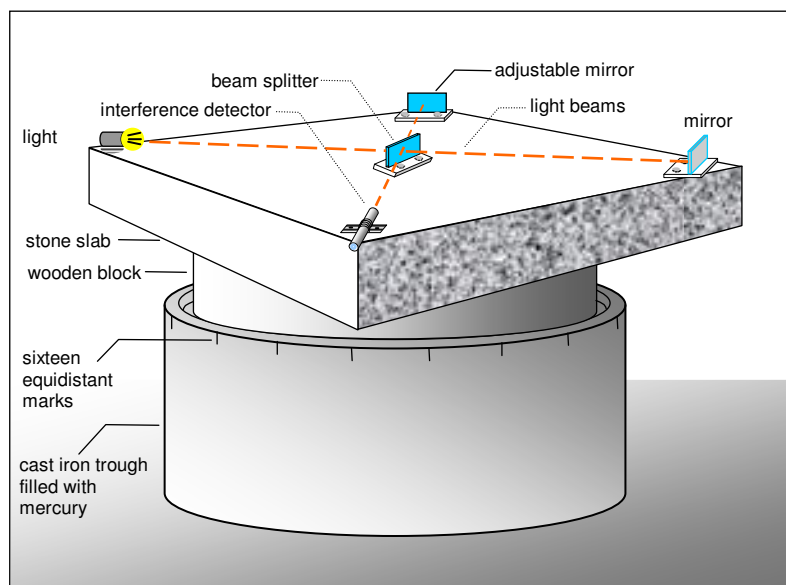

**Fig. 1.** Simplified representation of the Michelson-Morley 1887 apparatus. The light rays traveled along two perpendicular 'arms' pre-adjusted so that their lengths are equal. As the floating interferometer was slowly rotated, the amplitude of the fringe shift was observed through the telescope and recorded at sixteen intervals corresponding to the marks on the circumference of the cast iron trough.

It is useful to realize that light-path length-difference is equivalent to a time-of-travel difference. (The difference arises in spite of the fact that the ‘arms’ are adjusted so that they have the identical length  $d$ .) Furthermore, the difference is indicative of light speed anisotropy. The appearance of a fringe shift in a Michelson-interferometer experiment means that the speed of light is different in different directions! The interpretation is unequivocal.

The Michelson-interferometer experiment, with variations, has been repeated many times during the 20<sup>th</sup> century. The tests made by Dayton Miller were the most extensive and detailed —and undoubtedly the most conclusive. For what follows, it is important to understand that the Michelson-interferometer experiment can be conducted in vacuum mode and in gas mode. In the first, the light beams travel through an artificially created vacuum, in the other, they travel through a gas, usually air.

The results are radically different.

**5-2 ESR and Extended Theory make Radically Different Predictions**

As pointed out earlier, Einstein’s relativity is a theory of apparent effects, the Extended theory is one of apparent *and absolute* effects. Now let us compare how these theories explain the observations of a pair of straight-forward experiments. The first, the vacuum-mode experiment, has been repeatedly cited as supporting ESR and proving that aether does not exist or at least is non-detectable. Meanwhile, the second, the gas-mode interferometer experiment, has been repeatedly cited as supporting the existence of aether. (See [Table VI](#))

**Table VI**

Non-aether Relativity Theory vs New Aether Theory			
Experiment (As a test of aether-space by displaying light speed anisotropy)	Observation	ESR Explanation	DSSU Explanation
<b>Vacuum-Mode</b> Michelson Interferometer: (Georg Joos, 1930, Jena, Germany) (H. Müller, 2003)	Null result (no fringe shift)	<b>YES</b> —Aether does not exist or is undetectable. — $c$ is constant in all directions.	<b>YES</b> —Evidence of Lorentz contraction caused by aether-space flow. — $c$ is constant wrt aether-space.
<b>Gas-Mode</b> Michelson Interferometer: (Michelson & Morley, 1887) (Miller, 1933) (K. Illingworth, 1927)*	Positive result (fringe shift)	<b>NO</b>	<b>YES</b> —Evidence of aether-space flow which causes a change in the path length of light beams.  — $c$ is constant wrt aether-space.

\* Fringe shifts were observed but original report summarized the results as null. Once the refractive index of the helium gas is taken into account the Illingworth experiment is consistent with basic air-mode experiments. A similar reanalysis applies to the experiment by Jaseja T.S. *et al.* of 1964.

The table demonstrates four important points: (1) ESR is incomplete. (2) The vacuum-mode result has two interpretations. (3) DSSU relativity is a broader theory —it can explain comparatively more experimental evidence. (4) The superiority of the DSSU predictions and hence its “assumptions.”

ESR has no explanation for the *Gas-Mode Michelson Interferometer*. This is why Einstein was gravely concerned about Dayton Miller’s observations. This is why relativists tell us that the results fall outside the domain of ESR. The Extended theory explains both. All else being equal, a theory that explains two experiments is preferred to a theory that explains only one.

Then there is the deeper question behind the speed of light. Although ESR gives an operational definition of simultaneity and time-interval at different places, which definition by its nature makes the speed of a light pulse *constant* in all directions, ESR does not say how that speed is *fundamentally* defined. Although ESR says how to measure its magnitude with synchronized clocks and meter sticks, it does not say *what is it that defines the magnitude* —makes it 300,000 km/s and not 100,000 km/s. Einstein’s geometric space does not, and cannot, say. Einstein’s space is empty space. Consider Poincaré’s argument. "If light takes several years to reach us from a distant star, it is no longer on the star, nor is it on the earth. It must be somewhere, and supported, so to speak, by some material agency." It was clear to Poincaré that *empty space* just will not work. ... DSSU theory defines it *fundamentally* with respect to aether-space —a light-conducting luminiferous aether. This feature is used in the explanation (in [Table VI](#)) of the gas-mode positive results. All else being equal, a theory that gives physical meaning to the speed of light is superior to a theory that does not.

As a preliminary to a detailed explanation for the vacuum- and gas-mode results, it is important to discuss the two aspects of length contraction in the context of the extended theory.

### 5-3 Actual Length Contraction and Apparent Length Contraction

The explanation of the Michelson-interferometer results hinges on an understanding of the difference between *actual*, or absolute, length contraction and *apparent* length contraction.

Some terminology. *Actual* (i.e., absolute, aether referenced) length contraction is observer independent; and, *apparent* length contraction is observer dependent. *Apparent* length contraction of objects is the relativistic effect discussed in basic textbooks on the subject. And note carefully, *actual length*  $L_{\text{abs}}$ , herein, does not have the same meaning as *proper length*  $L_0$ . The *proper length*,  $L_0$ , of an object is the space interval between its ends measured in the rest frame of the object (with total disregard to relative or absolute motion).

The laboratory and the interferometer apparatus and the experimenter/observer are all in the same frame of reference—a frame that is moving through aether-space. (This frame is moving in orbit about the Sun and, along with the entire Solar System, in orbit about the Galaxy.) The motion through aether-space causes actual length contraction—specifically that of the stone slab that secures the functional arms of the Michelson apparatus. But because the experimenter and his experiment are both in the same frame there is no way to directly observe or measure the physical contraction taking place. Any attempt to measure the contraction with a “measuring rod” will fail, since the rod itself will shrink in length. However, the absolute length contraction can be calculated.

To find the *actual* length contraction of an object we need to determine its absolute speed with respect to aether-space (local aether-space). The observer, in this whole procedure, is irrelevant. The procedure, in terms of Extended relativity, requires that one frame is designated as the aether rest-frame (say “A”) and the other as the object/slab frame (say “B”). The procedure, in terms of the algebraic symbols, requires velocity magnitudes  $v_A = 0$  and  $v_B = v_{\text{Device}} = \text{speed-of-slab-through-aether}$ . The procedure requires the Extended length-contraction equation of Fig. 10. The general expanded version is

$$L = \frac{\sqrt{1-(v_A/c)^2} \sqrt{1-(v_B/c)^2}}{1+(v_A v_B/c^2)} L_0. \quad (1)$$

By setting  $v_A = 0$  the general contracted length  $L$  becomes the intrinsic length contraction  $L_{\text{abs}}$ . The length  $L_0$  represents the ‘proper’ length of the slab, or part thereof, (the ‘proper’ length is simply the length as measured with a standard measuring rod). After the aforementioned speed substitutions are made,

$$L_{\text{abs}} = \sqrt{1-(v_D/c)^2} L_0, \quad \text{where } v_D \text{ is the abbreviation of } v_{\text{Device}}. \quad (2)$$

$$L_{\text{abs}} = \frac{L_0}{\gamma_D}, \quad \text{where } \gamma_D \text{ is the intrinsic Lorentz factor.} \quad (3)$$

A simple test. By inspection  $L_{\text{abs}}$  is, as it should be, always less than  $L_0$  since  $\gamma_D$  is always greater than unity.

This equation will be applied shortly. But first . . .

What about the phenomenon of *apparent* length contraction? . . . One immediately recognizes that, since there is no relative motion, no apparent contraction can possibly occur. After all, the observer and the interferometer apparatus share the same frame of reference and both are at rest therein.

Now, if eqn (1) really is an expression for *absolute and apparent* length contraction then it must agree with the fact of “no apparent contraction.” We test the equation. (The result should assure the reader of its validity.)

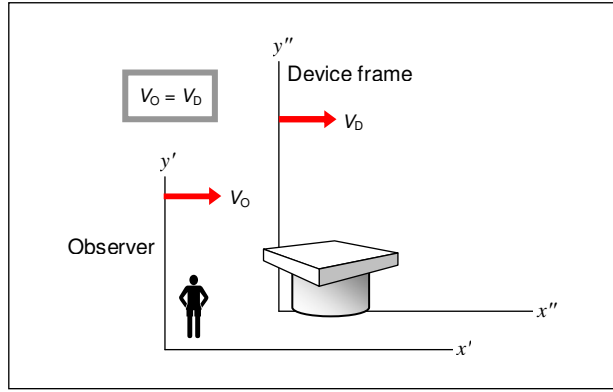

**Fig. 2.** *No length contraction observed under tandem motion.* The Observer has absolute motion *towards* the other frame; therefore, according to the sign rule,  $v_O$  is ‘-’. The interferometer device has absolute motion *away from* the other frame; thus  $v_D$  is ‘+’. The length contraction eqn (1) then reduces to  $L_{\text{apparent}} = L_0$ .

The Observer and the interferometer device are in tandem motion (absolute motion wrt aether) as shown in Fig. 2. The condition for tandem motion is that velocity vectors  $\mathbf{v}_O = \mathbf{v}_D$ . The reason for the ‘tandem’ qualifier is to establish an *offset* of the  $y$ -axes of the two frames. The problem with side-by-side motion is that the two  $y$ -axes will coincide. It’s a fine point but critical in the application of the sign rule. What it all means is that one frame’s motion is aimed towards the other, while the other’s motion is aimed away from the first. Net result: *No relative motion*.

The following substitutions are applied to eqn (1): one of the velocity magnitudes is  $v_O$  which is given a negative sign (because the motion is trying to decrease the distance between frames); the other is  $v_D$  and is positive (because the motion is trying to increase the distance between frames). Thus  $v_A = -v_O$  and  $v_B = +v_D$ . Also,  $L$  becomes  $L_{\text{apparent}}$ .

$$L_{\text{apparent}} = \frac{\sqrt{1 - (-v_O/c)^2} \sqrt{1 - (v_D/c)^2}}{1 + (-v_O v_D / c^2)} L_0, \text{ which reduces to}$$

$$L_{\text{apparent}} = L_0.$$

In other words the equation confirms that there is no *apparent* length contraction.

The remarkable feature of the DSSU contraction equation is that it codes both actual *and* apparent length contraction —giving justification for the term “extended” equation.

Recapping some important points: Only dimensions parallel to motion are contracted. Actual length contraction (which is also referred to as *absolute*, and *intrinsic*, contraction) is *length* referenced to the aether frame. It is observer independent. See Table VII.

**Table VII**

	Observer	Equation (Extended relativity)
Apparent length contraction: Eqn (4)	essential	$L_{\text{apparent}} = \frac{\sqrt{1 - (v_O/c)^2} \sqrt{1 - (v_D/c)^2}}{1 + (v_O v_D / c^2)} L_0 \quad (4)$
Actual length contraction: (wrt aether rest frame) Eqn (2)	irrelevant	$L_{\text{abs}} = \sqrt{1 - (v_D/c)^2} L_0 \quad (2)$ Observer has been removed from the general equation
Note: All speeds are with respect to aether-space and are collinear. Subscripts O and D refer to Observer and Device respectively.		

We are now ready to analyze the Michelson interferometer results; vacuum-mode results first.

#### 5-4 How DSSU Relativity Explains the Vacuum-Mode Interferometer Experiments

When the light beams of a Michelson interferometer are made to travel through a vacuum then the apparatus is said to be in vacuum mode.

The length of each of the two arms in the apparatus (shown schematically in Fig. 3) is defined by the distance between the beam splitter  $M$  and the corresponding mirrors  $M_1$  and  $M_2$ . Let  $d$  be the proper length of each arm (where “proper length” has the conventional meaning). The length of the arm that is perpendicular to the direction of motion through aether-space is not affected by the motion. But the parallel arm is affected. The rule in Extended relativity is that the dimensions of objects parallel to (or axial to) the direction of absolute motion undergo *actual* physical contraction. As mentioned earlier, this contraction cannot be measured by “measuring rods” because the rods themselves undergo identical contraction.

However, light can serve as a detector of length contraction. Since light is embedded (in the sense of being conducted) in the aether frame, we may say that it “senses” contracted lengths in the moving Apparatus Frame. The light “sees” length  $d$ , of the parallel arm, as  $d_{\text{con}}$ . In terms of actual length-contraction, eqn (2), we have

$$d_{\text{con}} = \sqrt{1 - (u/c)^2} \times d, \quad (5)$$

where  $u$  is the speed of the apparatus through aether-space.

Using the aether-space theory the speed of a light wave that the experimenter “sees” on the path  $MM_1$  is  $c - u$  (see Fig. 3). And for the return path  $M_1M$  it is  $c + u$ . The time required for a light wave to complete the round trip is

$$t_{\text{parallel}} = (\text{time along } MM_1) + (\text{time along } M_1M)$$

$$t_{\parallel} = \frac{d_{\text{con}}}{c - u} + \frac{d_{\text{con}}}{c + u} = d_{\text{con}} \frac{2c}{c^2 - u^2} = \frac{2d_{\text{con}}}{c} \times \frac{1}{1 - (u/c)^2}.$$

After substituting for  $d_{\text{con}}$ ,

$$t_{\parallel} = \frac{2d}{c} \times \frac{1}{\sqrt{1 - (u/c)^2}}.$$

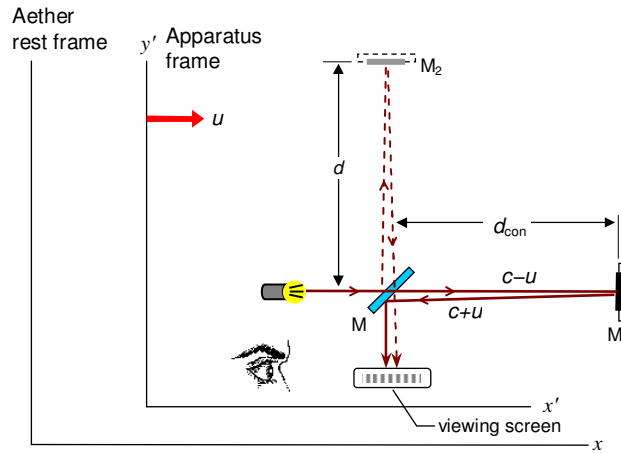

**Fig. 3.** Analysis of the speed of light waves along the “parallel” arm of a vac-mode Michelson interferometer (schematic plan view). The arm is parallel to the direction of absolute motion (i.e., motion through aether-space) and therefore undergoes *actual* length contraction. The contracted length is labeled as  $d_{\text{con}}$ .

Now for the perpendicular arm. The speed of a light wave, again using the aether-space theory, on path  $MM_2$  is  $\sqrt{c^2 - u^2}$  as shown in Fig. 4. The same speed holds for the return path  $M_2M$ , so that the time required for this arm's complete path is

$$t_{\perp} = 2 \frac{d}{\sqrt{c^2 - u^2}} = \frac{2d}{c} \times \frac{1}{\sqrt{1 - (u/c)^2}}.$$

The time difference for the two paths determines the interference-pattern fringe-shift expected (the prediction). The time difference between the parallel and perpendicular round trips is

$$\Delta t = t_{\parallel} - t_{\perp} = 0.$$

There is no time difference; thus, there should be no fringe shift whatsoever.

Actual observations confirm this prediction whenever the experiment is performed in vacuum mode. [8, 9, 10, 11, and 12]

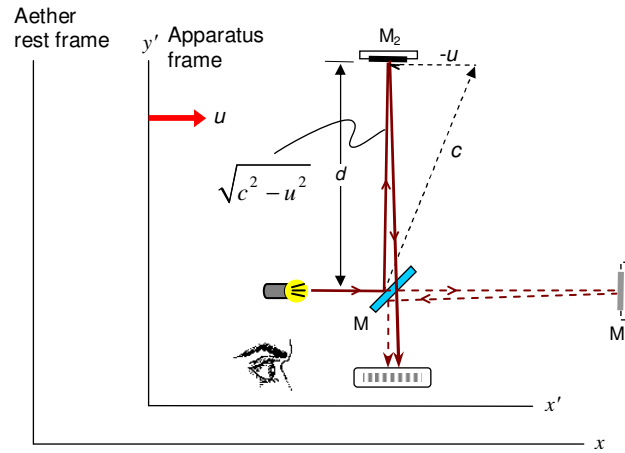

**Fig. 4.** Analysis of the velocity of light waves along the “perpendicular” arm of a vac-mode Michelson interferometer (schematic plan view). According to the aether-space theory, the light wave going from  $M$  to  $M_2$  travels with speed  $c$  *with respect to aether* along the diagonal dashed path. But it travels with speed  $(c^2 - u^2)^{1/2}$  with respect to the “moving” Apparatus/observer frame —as shown by the velocity-vector triangle. A similar analysis applies to the wave going from  $M_2$  back to  $M$ .

### 5-5 How DSSU Relativity Explains the Gas-Mode Interferometer Experiments

In gas-mode interferometer experiments one needs to take into consideration the index of refraction of the gas through which the light waves travel. The index of refraction  $n$  quantifies the slower speed that light travels through a transparent medium. Michelson and Morley, in the original 1887 experiment, used air, as did Miller in all his experiments from 1902 to 1926. The following analysis, then, takes into consideration that the speed of light in air is  $c/n$  where  $n$  for air equals 1.00029.

Noting that the parallel arm still represents an actual contracted length  $d_{\text{con}}$  given by eqn (5), we calculate the  $M$  to  $M_1$  to  $M$  round-trip time through air:

$$t_{\parallel} = \frac{d_{\text{con}}}{(c/n) - u} + \frac{d_{\text{con}}}{(c/n) + u} = 2d_{\text{con}} \frac{c/n}{(c/n)^2 - u^2} = \dots = 2d \frac{n}{c} \times \frac{\sqrt{1 - (u/c)^2}}{1 - (nu/c)^2}.$$

And along the perpendicular arm the round-trip time, through air, is:

$$t_{\perp} = 2 \frac{d}{\sqrt{(c/n)^2 - u^2}} = \dots = 2d \frac{n}{c} \times \frac{1}{\sqrt{1 - (nu/c)^2}}.$$

The time difference for the two paths is now,

$$\Delta t = t_{\parallel} - t_{\perp}$$

$$\Delta t = 2d \frac{n}{c} \left[ \frac{\sqrt{1 - (u/c)^2}}{1 - (nu/c)^2} - \frac{1}{\sqrt{1 - (nu/c)^2}} \right] = \dots = d \frac{u^2}{c^3} \times n(n^2 - 1).$$

This time difference causes a phase shift between the two beams and shows up as an interference pattern.

The actual fringe shift is the result of the time difference from one instrument-reading *plus* the time difference from a second reading —with the apparatus having been rotated 90° between the recording of the 1<sup>st</sup> and 2<sup>nd</sup> readings. Thus the recorded fringe shift is determined by,

$$2\Delta t = 2d \frac{u^2}{c^3} k, \text{ where } k = n(n^2 - 1). \quad (6)$$

We want to find  $u$  the absolute speed of the Apparatus through aether-space. Rearranging the equation gives,

$$u^2 = \frac{2\Delta t \times c^3}{2d \times k_{air}}. \quad (7)$$

With  $n = 1.00029$  the factor  $k_{air} = 5.8025 \times 10^{-4}$ .

Michelson and Morley, in 1887, had expected a maximum fringe shift of 0.40 as give by  $2\Delta t/T$  where  $T (= \lambda/c)$  is the period of vibration of the light. The wavelength  $\lambda$  was  $5.9 \times 10^{-7}$  meter. The maximum fringe shift they actually measured ranged between 0.01 and 0.02 (or between 1/20<sup>th</sup> and 1/40<sup>th</sup> of the expected 0.40). This corresponds to a time difference for  $2\Delta t$  of about  $2.0 \times 10^{-17}$  sec to  $4.0 \times 10^{-17}$  sec. [13]

When all the substitutions are made one finds the corresponding absolute velocity magnitudes:

$$u_{low} = \left( \frac{2.0 \times 10^{-17} \text{ s} \times (3.0 \times 10^8 \text{ m/s})^3}{2 \times 11 \text{ m} \times (5.8025 \times 10^{-4})} \right)^{1/2} \approx 206 \text{ km/s},$$

$$u_{high} = \dots \approx 290 \text{ km/s}$$

Without ever realizing it, Michelson and Morley had measured a speed, for what they called the “aether wind,” that ranged between 206 km/s and 290 km/s!

The aether theory that Michelson and Morley had used did not predict length contraction and so they did not consider the foreshortening of the parallel arm. They did of course consider the index of refraction on the speed of light. If we repeat the above analysis —but ignore the length contraction— we readily find what Michelson and Morley found. The peak values are in the range of only 5 to 7 km/s —far below the minimum peak of 30 km/s they had expected.

Michelson and Morley essentially had proved that the 19<sup>th</sup> century aether model was untenable.

### 5-6 The Miller Experiments

While the experiments of Michelson (1881 to 1887) were the first attempts to detect aether, the experiments of Dayton Miller were the most extensive and the most detailed in modern history. They began with a 1902 experiment (with the participation of Edward Morley); included the definitive work of 1925-1926 on Mt Wilson; and continued back in Cleveland where they ended in 1929. Miller, a highly

respected American physicist, greatly increased the sensitivity of the Michelson optical interferometer. He did this mainly by making the physical arm-length 430 cm and making the effective length between mirrors 32 meters (about 3 times the corresponding lengths in the 1887 experiment). He also increased the sensitivity by conducting the experiment at a more favourable geographical latitude (Miller had sought altitude, the fortuitous latitude was a chance bonus). Over many years different structural materials and procedural techniques were tested; these experiments produced consistently positive results. Notably, the measurements taken on Mt. Wilson, in California, always corresponded to an aether speed of about 10 km/s. This speed would “appear” twice daily as a min/max on a sinusoidal graph of fringe displacements recorded in a 24 hour period.

Miller, of course, used the old aether theory to arrive at the aether maximum speed in the range of 10 km/s; he confessed his failure to understand why measurements were so low.<sup>14</sup> In conformity with the old theory, Miller did not consider the length contraction of the apparatus, at least not in the calculations. But he did have a plan.

In all the aether experiments prior to 1925, the direction of relative motion between Earth and aether had been assumed.<sup>15</sup> With the definitive Mt Wilson experiments, Miller discarded the assumption of Earth orbiting through a static aether and set out to actually measure the direction of absolute motion. The magnitude of the aether flow would then follow —it would follow from a truly ingenious method.

Miller logically assumed that there should be two components<sup>D</sup> making up the resultant aether-flow vector. One representing the aether flow due to Earth's orbital velocity (a known quantity) and the other representing the aether flow caused by the entire Solar system's motion (the unknown quantity) through galactic space. Incidentally, this makes it clear that Miller was thinking of a moving *static aether* and *not* a gravitational aether.

Miller's idea is somewhat analogous to using the phenomenon of the *aberration of light* and the velocity of Earth to determine the velocity of light coming from a distant star. James Bradley, an English astronomer, in 1729 used the angle of aberration —an angle that required making accurate measurements of a favourably located star at 6-month intervals— and the known velocity of the Earth's orbital motion about the Sun to determine the velocity of light. Using the fact that the trigonometric tangent of the aberration angle is, for a simple case, the ratio of the speed of the Earth to that of light, Bradley was able to calculate the speed of light to be 304,000 km/s. [<sup>16</sup>] [<sup>17</sup>]

The essential point, which Bradley turned to his advantage, was that the actual displacement of starlight, caused by the aberration effect, cannot be directly observed —but the *changes* in this displacement can.<sup>18</sup> It takes six months of patience, though.

An interesting historical note is that Bradley's work was correctly interpreted as proving that if there is an aether, then the Earth is moving *through* it.<sup>19</sup> More than a century and a half later the Michelson & Morley experiment was incorrectly interpreted as demonstrating that if there is an aether, it moves *with* the Earth! So that, in effect, the Earth is at rest in it.

The method that Miller used was considerably more elaborate than Bradley's; however, the principle idea was the same. Measure the aberration of the incoming aether velocity, recognize that the aberration is caused by the Earth's orbital motion, and use the known velocity of that same orbital motion when doing the calculations. Bradley had taken two readings 6 months apart and obtained an aberration displacement; Miller took readings at four different times of the year and obtained (by interpolation) an aberration circle.

Fig. 5 shows the two vectors Miller had in mind as well as the aberration circle, formed by the orbital component. The aberration circle actually belongs in the *ecliptic plane* (in which plane the effect is maximum) but is shown here schematically projected onto the *equatorial plane* for clarity. One vector (labeled  $\mathbf{v}_{\text{aether cosmic}}$ ) represents the aether flowing through the Solar system. The other vector (labeled  $\mathbf{v}_{\text{aether orbital}}$ ) represents the aether flow caused solely by Earth's orbital motion. The latter changes direction (ccw in lock-step with Earth's ccw orbit) on a yearly cycle to produce the aberration circle. A line joining the ends of the vectors sweeps out a cone (not shown). The direction of the cone is determined almost directly by the interferometer (by the intersection of the various min/max directions recorded during one year). The base of the cone is the aberration circle. But the height of the cone was unknown.

<sup>D</sup> There was also a third component. “The rotation of the earth on its axis produces a velocity of less than four-tenths of a kilometer per second in the latitude of observation and is negligible as far as the velocity of absolute motion is concerned ...” —Miller, D.C. **Reviews of Modern Physics**, Vol. 5 July, 1933, p223

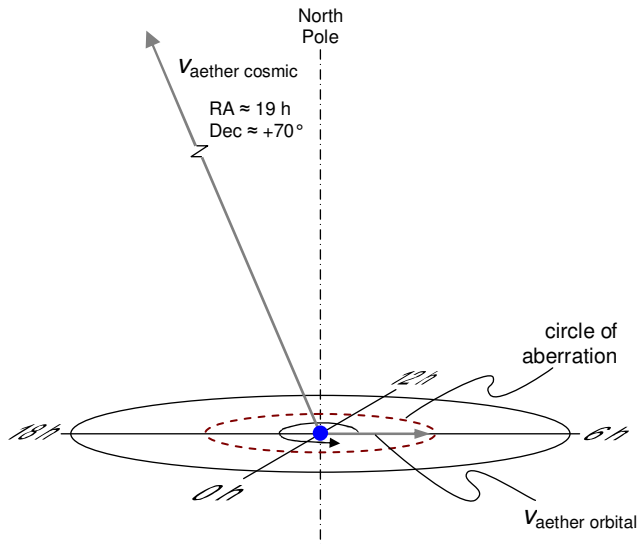
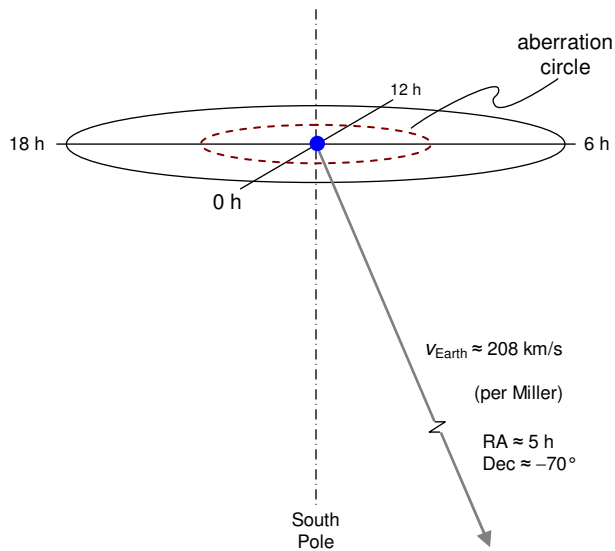

**Fig. 5.** The circle of aberration was Miller's conceptual key for deducing the magnitude of the cosmic component of aether flow. The aberration circle is formed by the vector that represents the aether flow produced by Earth's orbital motion. Although the aberration effect is maximum in the Ecliptic plane, it is shown, for clarity, projected onto the Equatorial plane. The apex of the  $v_{\text{aether cosmic}}$  velocity vector and the aberration circle form a cone that was key to Miller's method of deducing the speed of the cosmic aether flow.

Now, here is the key to Millers method. He had another cone —same axis direction but much smaller. The axis of the smaller cone represented the measured aether wind derived, by the old method, from the max fringe shifts. Like a problem in solid geometry, Miller compared two *similar* cones: One with a known base (the measured aberration circle with a radius representing 30 km/s); the other cone with a known axis (representing the measured nominal 10 km/s aether flow) and known angles (obtained from the measured directions of maximum aether flow).

By figuratively enlarging the smaller cone to the size of the larger —essentially the base of the smaller cone is enlarged so that it coincides with the aberration circle— it is easy to see how the 10 km/s became magnified into the 208 km/s that Miller reported in his 1933 paper.

Miller had (i) measured the direction and (ii) deduced the speed. He had thus succeeded in attaining the two goals he had set for the 1925-26 Mt. Wilson tests. Although the instrument measured an aether speed of only 10 km/s, Miller deduced an actual speed of 208 km/s.



**Fig. 6.** Miller's results. Net absolute velocity of Earth is approximately Right Ascension 5 h, Declination 70°S, and has an average magnitude of 208 km/s. (Oddly, Miller used an Earth-motion vector instead of an aether-flow vector.)

In the 1933 report, Miller shows vectors representing the Earth's motion through aether (not as vectors of aether flow, as I have done in Fig. 5). This can be a source of confusion for the unwary. ... A momentary disorientation may be encountered when one looks at a representation of Miller's perspective (see Fig. 6). It appears as though the Earth is traveling away from its own coordinate system. This confusion does not arise in Fig. 5 in which aether clearly flows through a fixed coordinate system. Miller does not help matters by discussing, in the text, the conceptual opposites of "net motion of the Earth" pushing through the aether versus the "direction of [a]ether-drift."

Anyway, the Miller paper concluded that the absolute motion of the Earth has an average magnitude of 208 km/s and a net direction Right Ascension 5h and Declination  $-70^\circ$  as in Fig. 6. This, of course, is entirely equivalent to saying that the aether wind is 208 km/s in the  $180^\circ$  opposite direction, namely, RA 19h, Dec  $+70^\circ$  (as was done earlier in Fig. 5).<sup>E</sup>

### 5-7 The Aether Velocity Component that Miller did not Consider

Miller knew that Earth's motion through aether causes observational aberration. What he did not know, since it was not part of the contemporary aether model that he used, is that the space medium is actually a gravitational aether. (As noted earlier in Table I, last row: aether-space is dynamic in the sense of producing gravitational effects.) He did not know there was a Solar-centric aether flow. In fact, the Solar inflow has a speed even greater than Earth's orbital speed and is easily calculated. The Solar inflow vector is just the negative of the escape velocity, with respect to the Sun, at the distance of Earth's orbit. The magnitude of the inflow is 42.2 km/s.

Thus the radius of the aberration circle is determined by both the orbital motion as well as the Sun's gravitational action (a manifestation of the dynamic aspect of DSSU aether). Adding the respective vectors, as shown in Fig. 7, gives a net aberration speed of 52 km/s.

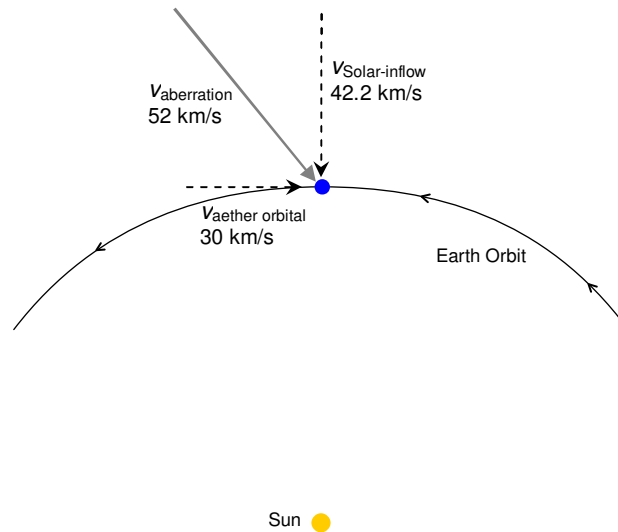
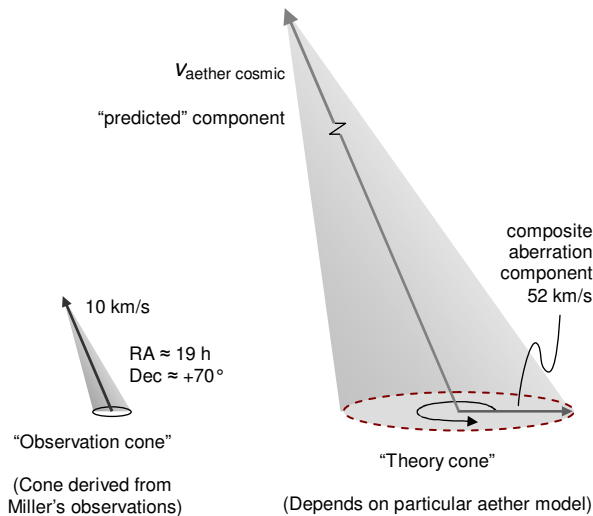

**Fig. 7.** Determining the net aether velocity (with respect to Earth) in the plane of the ecliptic. The motion component,  $v_{\text{aether orbital}}$ , and the gravitational component,  $v_{\text{Solar-inflow}}$ , when combined will serve as the *net aberration velocity* of 52 km/s. The Solar-inflow aether-vector is equal to the negative of the escape velocity, with respect to the Sun, at the distance of Earth's orbit.

The radius of Miller's aberration circle should thus be increased to 52 km/s.

When Miller scaled the "observation cone" to fit his simple (one component) 30 km/s aberration circle, his model predicted a cosmic aether flow of 208 km/s. If Miller had scaled the "observation cone" to fit the *composite* aberration-circle of the "theory cone", he would have predicted a significantly larger cosmic aether flow of 360 km/s. See Fig. 8.

<sup>E</sup> While Miller's 1933 paper concluded that the Earth was moving *through the aether* towards the Southern constellation Dorado, near the southern pole of the Plane of the Ecliptic, the movement and direction of aether-drift past the interferometer was exactly opposite—it was towards Draco near the northern pole of the Plane of the Ecliptic.



**Fig. 8.** Schematic of Miller's "Observation cone" and "Theory cone". The DSSU aether theory requires the use of the *composite* aberration-velocity of 52 km/s. By scaling the observation cone to coincide with the aberration circle (of the theory cone), one may predict that the cosmic aether flow ( $= 208 \times 52/30$ ) equals 360 km/s

The value of 360 km/s that can be predicted from the Miller data in the light of a gravitational aether is within 13.8% of the modern experimental value of 418 km/s obtained by Australian physicist Reginald T. Cahill in 2006.<sup>[20]</sup> Significantly, the Cahill experiment was not a gas-mode Michelson interferometer.

The DSSU analysis result is also supported by the findings of the Roland DeWitte experiment conducted in Brussels, in 1991. The DeWitte coaxial cable experiment (a 1<sup>st</sup>-order effect device) using atomic clocks revealed a speed of absolute motion of approximately 400 km/s.<sup>21</sup>

In summary, what the historical evidence has shown and the contemporary experimental evidence continues to show is the existence of aether flow and absolute motion. The measurements, in these experiments, actually record the speed of light as being *different* in different directions. Light speed anisotropy within an absolute-motion frame is predicted by the Extended theory and verified by observations —in direct contradiction to Einstein's theory.

Let me conclude section 5 by referring the reader back to [Table VI](#). Remarkably, ESR has no explanation!<sup>F</sup> The ESR postulate demands that the speed of light in vacuum be the same in all directions. The speed of light Postulate when applied to air means: The speed of light in air has the same value  $c/n_{\text{air}}$  in all directions, where  $n_{\text{air}}$  is the index of refraction ( $= 0.00029$ ). And yet it is not so. Light speed anisotropy was first discovered in 1887. Over the years several other experiments rediscovered the anisotropy. The most recent was in 2006. It was conducted by Professor Cahill and involved a new method. His experiment was a coaxial cable and fiber optic arrangement in which light-pulse travel *time* was being measured, instead of light-pulse path *length* (as in the Michelson interferometer). Atomic clocks were used to record the difference in pulse travel time.<sup>22</sup>

## 6 Extended Relativity Equations

There are only two properties embedded in the Lorentz transformations: Time is a function of motion. The speed of light is constant.

The Lorentz transformations are not concerned with the nature of *space* itself —whether it is an empty geometric abstraction or a permeation of a quasi-physical medium. The properties of space are entirely subject to the particulars of the theory to which the Lorentz transformations are applied.

This allowed Einstein to apply the Lorentz transformations to non-absolute geometric space and thereby *generate the whole theory of special relativity*.

Likewise, it allowed the Lorentz transformations to be applied to aether-space to formulate the Extended Lorentz transformations which, in turn, *generated the whole symmetrical domain of Extended*

<sup>F</sup> ESR has no explanation for the fact that light (as it travels between the mirrors) appears to travel at one speed along the directional axis of aether flow and a different speed across the direction of aether flow. Now if acceleration or gravity were involved then, yes, ESR does accommodate light speed anisotropy and does have a perfectly sound explanation. But gravity and acceleration are *not* involved in the interferometer experiments. The light paths in the apparatus are all directed in a neutral direction as far as the downward direction of Earth's gravity is concerned. The apparatus is *not* accelerating in the horizontal plane!

relativity.

The following flowcharts present several Extended relativity equations<sup>23</sup> and how they relate to Einsteinian physics and to Galilean-Newtonian physics. The sign rules that apply to many of the equations are discussed in the Appendix.

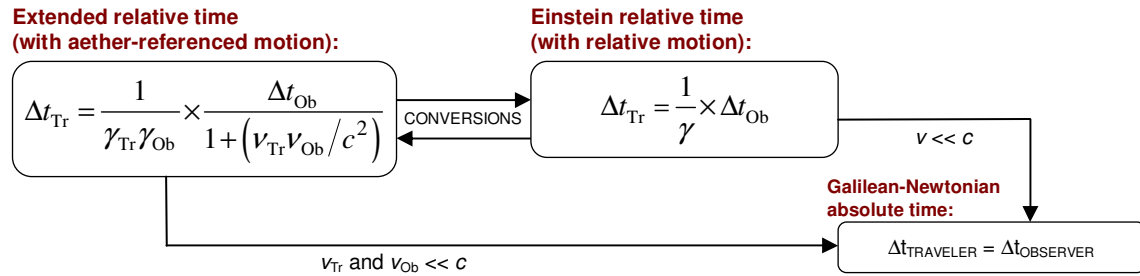

**Fig. 9.** Extended relativity *time equation* and how it relates to *special relativity* and *classical relativity*. When all speeds are restricted to low speeds the equations reduce to the classical Galilean-Newtonian form. (The “conversion” procedure is described in the text. The Lorentz factors are detailed in Table V.)

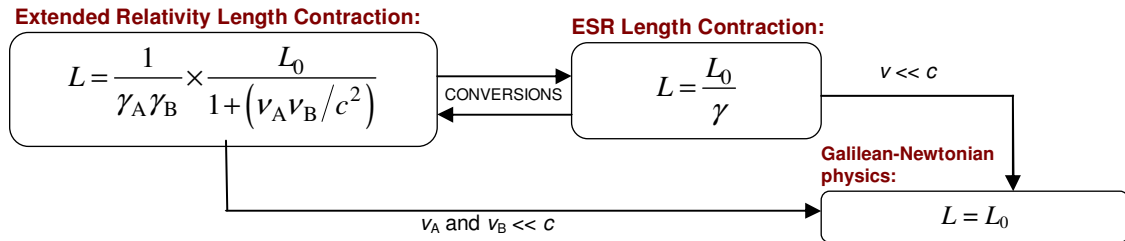

**Fig. 10.** Extended relativity *length-contraction equation* and how it relates to *special relativity* and classical physics. When speeds are restricted to low speeds the equations reduce to the Galilean-Newtonian form. (The “conversion” procedure is described in the text. The Lorentz factors are detailed in Table V.)

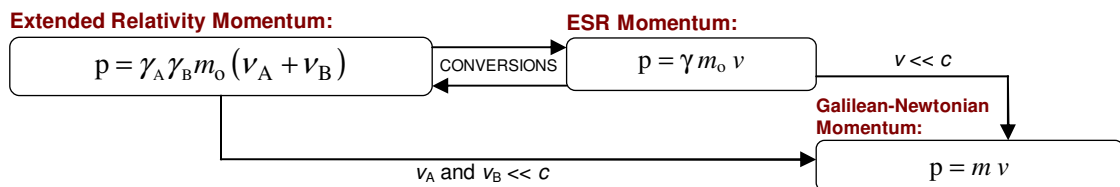

**Fig. 11.** Extended relativity *momentum equation* and how it relates to *special relativity* and classical physics. When speeds are restricted to low speeds the equations reduce to the Galilean-Newtonian form. (The “conversion” procedure is described in the text. The Lorentz factors are detailed in Table V.)

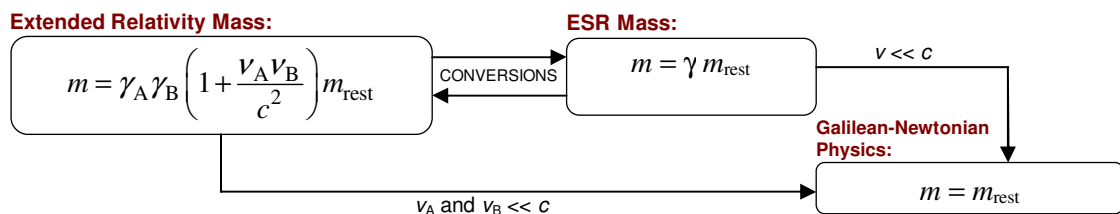

**Fig. 12.** Extended relativity *mass equation* and how it relates to *special relativity* and classical physics. When speeds are restricted to low speeds the equations reduce to the Galilean-Newtonian form. (The “conversion” procedure is described in the text. The Lorentz factors are detailed in Table V.)

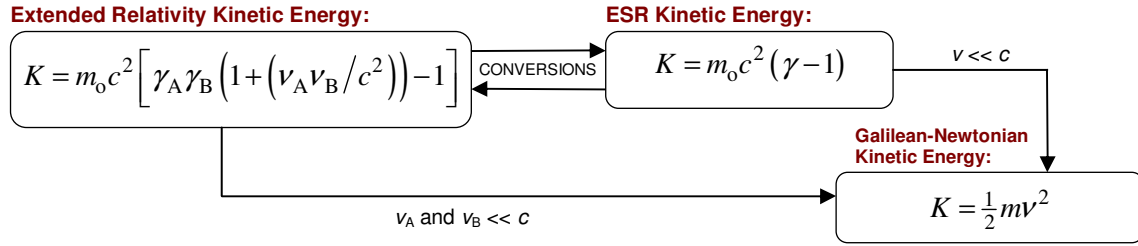

**Fig. 13.** Extended relativity *kinetic energy equation* and how it relates to *special relativity* and classical physics. When speeds are restricted to low speeds the equations reduce to the Galilean-Newtonian form. (The “conversion” procedure is described in the text. The Lorentz factors are detailed in [Table V](#).)

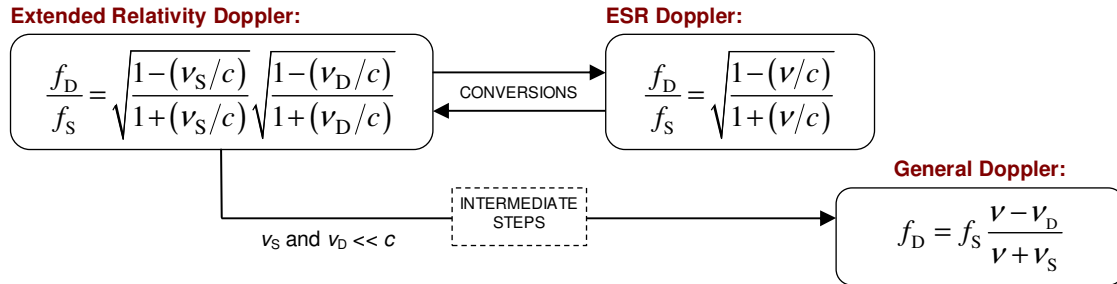

**Fig. 14.** Extended relativity *Doppler equation* and how it relates to the *special relativity Doppler* and the *classical Doppler*. All subscripted speeds/velocities are referenced to the wave propagating medium —aether-space in the case of the Extended eqn, and air, water, etc., in the case of the General Doppler eqn. It is important to note that (i) the Extended eqn is completely general within its domain of aether-referenced motion, and (ii) the Einstein Doppler eqn is completely general within its domain of pure relative motion.  $f_S$  and  $f_D$  are the wave frequencies emitted by the Source and received by the Detector, respectively. (The procedures for the equation “conversions” are described in the text.)

The Extended relativity expressions all use aether-referenced motions. The corresponding ESR equation all use a single (shared) relative velocity between observer and target. The conversion involves two kinds of velocities —one that is absolute and observer independent, and another that is relative and observer dependent. Here is how we convert from two absolute velocities to a single relative velocity: An observer in A-frame “sees” that his own frame has a relative speed of zero (obviously) and that B-frame has a relative motion  $v$ . The method simply requires one to replace the frame velocities  $v_A$  and  $v_B$ , in the Extended equation, with the *apparent* velocities 0 and  $v$ . One ends up with the corresponding ESR equation.

Now for the conversion from Einstein relativity to Extended relativity. Simply substitute the following expression for  $v$  (see Appendix II, [eqn \(A18\)](#)).

$$v = \frac{v_A + v_B}{1 + (v_A v_B / c^2)}. \quad (8)$$

Used as a key for equation conversions, this formula allows a pure relative motion to be expressed in terms of the separate absolute motions of the observer and the subject. (Alternately, the formula converts the absolute velocities, of two frames of reference, into a single relative velocity for an observer in either of the two frames.) When [eqn \(8\)](#) is substituted into any ESR equation, one essentially ends up with the corresponding Extended relativity expression. (Be reminded that the substitution also applies to the “ $v$ ” inside the Lorentz factor.)

Some points of comparison to keep in mind: In Einstein’s relativity, lightspeed is constant (by definition); in Extended relativity, lightspeed is constant with respect to aether, but at the same time giving the remarkable illusion that it is constant with respect to any observer, regardless of motion.

Both ESR & DSSU can agree on situations of time dilation and on the apparent clock-time that arises between relatively moving frames. ESR, however, is limited to the *apparent* time aspect, while DSSU can handle both *apparent* and (when referenced to the aether frame) *intrinsic* time. In fact, in the extended theory it is possible to define four clock “times.” See adjacent text box.

Another point of agreement. Einstein's space and DSSU's aether-space are both non-static. (In this respect, DSSU represents a significant departure from Lorentz's aether, which was static.) They are both dynamic; and being dynamic is the key to a functional universe. Einstein's geometric space is *geometrodynamic* (mathematically dynamic). DSSU space is quasi-physically dynamic. DSSU aether-space can do, physically, most anything that Einstein's metric-space can do. (1) When *Einstein's space* curves hyperbolically, *DSSU space* physically expands. (2) When *Einstein's space* curves spherically, *DSSU space* physically contracts. It is a telling coincidence that Einstein sometimes called it *contractile* curvature. (3) The Lense-Thirring frame-dragging effect corresponds to an inward spiraling aether flow. (4) Gravitational lensing is explained by the fact that DSSU space is both luminiferous *and* gravitational. (5) However, DSSU aether cannot radiate Einstein's gravitational waves (but this is not a problem since they have never been detected).

Under the Extended relativity theory aether-space becomes an intimate component. Clock time and object length still depend on relative motion, including relative to aether-space. Light propagation still gives the two-way illusion of constancy, but it also gives non-illusion effects. Moreover, “space” is still dynamic, but now responding to the presence of objects with something more substantive than “curvature” by responding with physical dynamic processes (see paragraph above). These “extended” features are embedded in the various equations.

The remarkable feature of Extended relativity is that, in spite of the introduction of a preferred frame (the aether frame), and in spite of the fundamentally different methods, the various equations (Figs 9 to 14) will give the very same answer as the corresponding ESR equation. As far as the algebra is concerned, the conversions ensure that the DSSU and ESR equations give the same result for the same situation.<sup>G</sup>

Now, since DSSU relativity can also deal with absolute-motion effects (as described in Section 8) it is clearly a broader theory. It encompasses the observables of the Einstein theory, encompasses aspects of the Lorentz theory, encompasses a detectable aether, and is therefore justified in being called *Extended relativity*.

#### Clock Time

***Intrinsic time*** is what clocks measure while stationary in aether OR moving through aether. To observe intrinsic time one must be moving WITH the clock.

***Apparent time*** arises when an observer measures the clock time (or clock rate) of a relatively moving clock. The motion of the aether is of no relevance. *Different observers are able to “see” different rates for the same clock!*

***Absolute time*** is what a clock measures when at rest with respect to aether.

***Universe time*** may be said to exist on the cosmic scale, but because aether-space is everywhere involved in dynamic motion, it serves little purpose. Universe time is measurable ONLY at the Lagrangian nodes of the cosmic cell structure of the cellular universe (the non-expanding DSSU).

And yet, “time” itself, independent of clock time, has no meaning. In the DSSU theory *time* has no independent existence. *Time* is simply a mathematical convenience for comparing motion.

## 7 Loophole in the Second Postulate

The measure of the speed of anything is meaningless without employing a time interval. Also, when timing the motion between two points separated by some distance, we need to be sure that the timing device at the “start” point agrees with a similar device at the “end” point. They need to display the same time for each simultaneous instant. They need to be synchronized. How then, aside from technical considerations, are the *time interval* and *simultaneity* to be defined?

Einstein recognized that these were essential concepts for relativity theory and necessitated a system of synchronized clocks. Furthermore, he understood that in a discussion at this fundamental level the intuitive notion of time intervals (say, between events at different places) is inadequate. And so, he devised an operational definition of simultaneity and time-interval at different places as follows: Suppose time-intervals at different points (points *A* and *B*) of a given coordinate system are measured by clocks of

<sup>G</sup> With the current progress in the development of “table top” models of absolute motion detectors the aether-referenced method may soon be feasible.

similar construction; we may then synchronize these clocks by means of light signals. *A* emits a light ray at time  $t_A$  by *A*’s clock, it is received and reflected by *B* at time  $t_B$  by *B*’s clock, and returns to *A* at  $t'_A$  by *A*’s clock. Then *B*’s time  $t_B$  is *defined* to be simultaneous with *A*’s time  $\frac{1}{2}(t'_A + t_A)$ . [24]

What is significant is that this definition makes the speed of light the same in both directions (directions *AB* and *BA*) by virtue of the time interval employed. And when extended to any pair of relatively moving observers (in uniform motion) it makes the speed of light, in a closed path, constant in all directions. [25] Furthermore, there has never been a violation of Einstein’s narrowly-defined speed of light. In fact, the Michelson-Morley type experiment when conducted in vacuum mode provides unequivocal confirmation for the definition.

Einstein’s operational definition gives meaning to *time interval* (and *simultaneity*) and is the veritable heart of relativity. Everything that has motion has a time-interval component. Thus, to check the synchronicity of the clocks, or conversely to check the speed of the light pulse, one must use the two-way method. This is so fundamental that it axiomatically becomes part of the speed of light Postulate. The observed speed-of-light invariance means that the speed measured by the two-way method (out-and-reflected-back method) must be constant. And so it is.

And therein lies the loophole.

If the two-way speed of light must be invariant, it does NOT mean that the *one-way measured* speed of light must also be invariant.

This loophole allows one to extend the lightspeed postulate to accommodate the one-way measuring method. And since the one-way measure has been theoretically and experimentally shown to be  $c' = c \pm v$ , (for small  $v$ ), we simply postulate that the one-way determined speed of light is *variant* —it varies with the motion of the observer.

Thus, Einstein’s historically-restricted Postulate can be modified to allow for both lightspeed *variance* and *invariance*. It is simply a matter of making the speed dependent on the measuring method.

The conditions under which *variance* and *invariance* occur are detailed in Table VIII. Note carefully that Einstein’s speed of light is *symmetrically relative*; meaning that it applies to all observers and all uniform relative motion. But the Extended speed of light is *non-symmetrically relative*; meaning that it varies according to the relative motion of the observer.

**Table VIII**

Speed of Light Comparison			
Two ways to define the speed of light	Speed relationship	Motion of observer	Measuring method
Measurable & symmetrically relative (ESR compliant):	$c_{\text{obs}} = \text{always } c$	Any uniform motion	Two-way-light-path (per Einstein’s definition)
Measurable & non-symmetrically relative (NOT ESR compliant):	$c_{\text{obs}} \begin{cases} < c \\ = c \\ > c \end{cases}$	Away from source At rest within aether Towards source	One-way-light-path

Table notes: The two-way-light-path method involves light pulses beamed out and reflected back to the observer. The Michelson interferometer uses this method. With the other, the one-way-light-path method, no reflection is involved. An example of this method is S.J.G. Gifts analysis of the Roemer effect (the variation in the period of Jupiter’s moon Io as observed from Earth from opposite sides of Earth’s solar orbit).

The speed of light postulate that governs the Extended theory actually has three components. (i) The speed of light is absolute with respect to aether (and has the constant value  $c$ ). (ii) The speed of light is *invariant* in agreement with the ESR *illusion* of constant lightspeed. This feature is the basis of *symmetrical relativity*. And (iii) the speed of light is *variant* in agreement with the presence of aether and experimental evidence [26, 27, 28]. This feature is the basis of *asymmetrical relative-motion effects*. These components are explored in some detail in ref [29].

## 8 Absolute Motion Effects

The Extended theory predicts certain physical changes; they are not easily recognized within the moving frame but are quite real nonetheless. For example, *intrinsic length contraction* is the reason a vacuum-mode Michelson-Morley optical experiment gives null results. *Intrinsic clock-slowness* is vital for the resolution of instances of the twin paradox. The following table gives the expressions for the intrinsic effects due to motion through aether-space. The speed through the aether determines the value of the intrinsic Lorentz factor which then serves as the proportionality parameter in the expressions.

**Table IX** Absolute (or intrinsic) motion effects for the *Extended theory*

Absolute Motion Effects		
Intrinsic Clock-Slowness	Intrinsic Length-Contraction	Intrinsic Mass
$\Delta t_{\text{Abs Rest}} = \gamma_A \Delta t_o$ <p>where <math>\Delta t_o</math> is A-frame’s conventional “proper” time.</p>	$L_{\text{intrinsic}} = \frac{L_o}{\gamma_A}$ <p>where <math>L_o</math> is the measured length in frame A. (<math>L_o</math> is the conventional “proper” length)</p>	$m_{\text{intrinsic}} = \gamma_A m_o$ <p>This mass is called intrinsic because it is <i>observer independent</i> mass. (<math>m_o</math> is the conventional rest mass)</p>
Clocks run ever more slowly with increase in speed through aether-space	The intrinsic length decreases with increase in speed through aether-space	The intrinsic mass increases with speed through aether-space. (At present, the implications and applicability of <i>intrinsic mass</i> is open to debate.)

*Intrinsic clock-slowness* might be expressed more intuitively as,  $\Delta t_A = \frac{\Delta t_{\text{Abs Rest}}}{\gamma_A}$ , where one tick on clock A corresponds to more than one tick on the *Abs-Rest* clock. That is, the clock in A-frame records *less* time than the *Abs-Rest* clock. (Keep in mind, when there is motion, the  $\gamma$ -factor is always greater than unity.)

## 9 Summary and Concluding Remarks

### 9-1 Extended Domains

Figure 15 (below) presents a schematic framework of the extended theory—a broad aether theory that encompasses the domain of absolute/intrinsic effects, the domain of symmetrical relativity, and the domain of asymmetrical effects.

Symmetrical relativity is based on the Extended Lorentz Transformations (Table V). In order to maintain symmetry and remain within this domain, a two-way light-path method is required when measuring the speed of light. Within this domain is the predicted illusion of the invariance of the speed of light<sup>30</sup>; for which there is considerable supporting experimental evidence. The Michelson-Morley experiment, in vacuum mode, is a good example.

Note that aether referencing is optional. The Symmetrical domain allows one to ignore the aether medium altogether, if one so chooses. Einstein did this with his special relativity. Say aether is ignored: then, when comparing the timing of events involving relative motion between observers, a system of clock synchronization becomes necessary. Einstein’s clock synchronization method is employed; and since it definitely is a two-way light-path method, we remain within the *symmetrical-relativity domain*. Although the presence of aether is being ignored, one still achieves the illusion of lightspeed invariance (as a direct consequence of the clock synchronization method).

The Nonsymmetrical domain is defined by a non-constant apparent speed of light—a variance that is supported by measurements based on the one-way light-path method.<sup>31 32</sup> The conversion of measurements between inertial reference frames may be achieved by various methods, including the use of ordinary Galilean transformations, suitably corrected for absolute motion effects, as detailed by Joseph Lévy<sup>33</sup>; and the use of “Inertial transformations” as detailed by Franco Selleri.<sup>34</sup>

What about the apparent contradiction between the two domains relating to the observed speed of light? Let me emphasize, the domain of Symmetrical Relativity is *defined* by lightspeed INVARIANCE. It is its foundation definition. The finding of evidence of lightspeed VARIANCE cannot change the definition. One cannot simply change the definition after the fact. If one does, then it is no longer the same theory. Change any one of Euclid’s five axioms, for example, and you no longer have a theory of Euclidean geometry.

Any experiment, by whatever means, that reveals one-way light speed VARIANCE must logically be

interpreted to mean that there is an additional theory. A different theory with its own set of definitions and postulates. Such a theory uses non-Lorentzian transformation equations and belongs in the domain of *nonsymmetrical effects* (Fig. 15, third column).

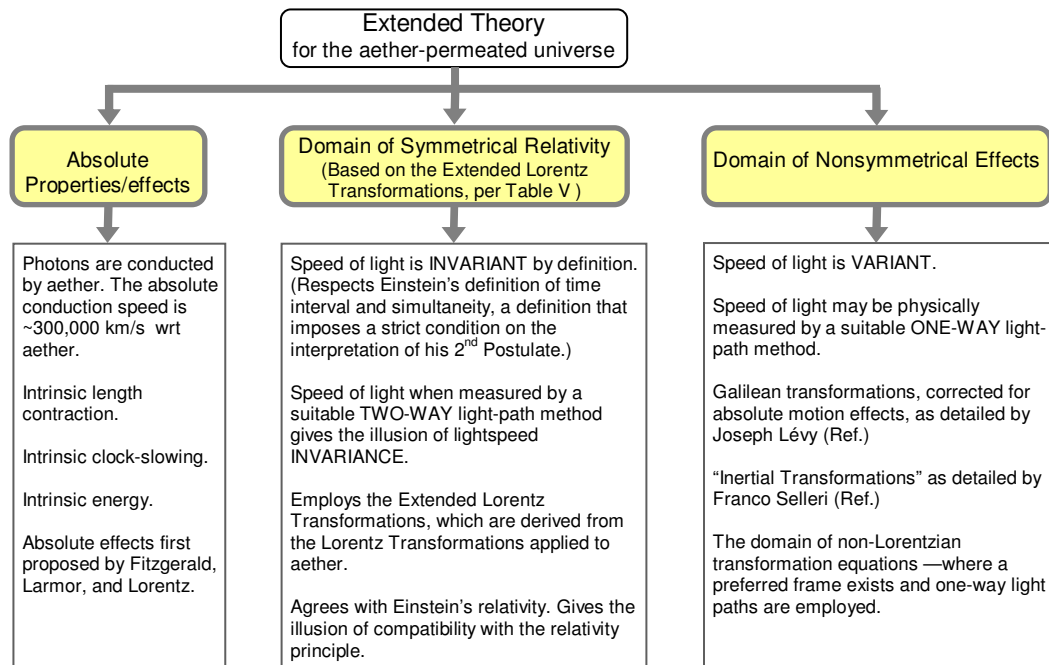

**Fig. 15.** Concept map of the extended theory —the theory of absolute- and relative- inertial-motion for the universe permeated by aether.

### 9-2 Another Loophole

ESR says that any frame of reference can serve equally well. It does not say *any frame except one!* What if one of those frames happens to be an actual, but unrecognized, preferred frame? ... ESR does not say “any frame is allowed except the one in which space or the vacuum of space (regardless of how it may be defined) is at rest.” To say a preferred frame is forbidden is another way of committing the fallacy of the converse.

What this means is that we are free to extend *special relativity* if we so choose by simply including the special frame. *Extended relativity* (Fig. 15, middle column) makes this explicit. It expands the ESR relativity postulate to include a special frame. The result is an aether theory in which *symmetrical relativity* continues to describe apparent effects (including the illusion of lightspeed invariance), while at the same time a space medium is made available to which we now attribute absolute effects (effects that do not depend on relative motion, Fig. 15, first column) and to which we also attribute *nonsymmetrical effects* (effects that *do* depend on relative motion, Fig. 15, third column).

### 9-3 Einstein's Problematic Hypothesis

Einstein's hypothesis holds that the speed of light is constant for all paths. When the analysis of the 1887 Michelson-Morley experiment is carried through on Einstein's hypothesis, null results are clearly predicted. The motion of the Earth around the Sun and the rotation of the interferometer have, in Einstein's view, no effect whatever on the speed of the light waves in the interferometer.<sup>35</sup> And as I have pointed out earlier, the vacuum mode Michelson-Morley experiment does support the Einstein hypothesis. However ...

*It should be made clear that although Einstein's hypothesis is completely consistent with the negative results of the [historically misinterpreted] Michelson-Morley experiment this experiment standing alone cannot serve as proof for Einstein's hypothesis. —D. Halliday & R. Resnick<sup>36</sup>*

Likewise (but more aptly), it should be made clear that although Einstein's hypothesis is completely consistent with the negative results of the *vacuum mode* Michelson-interferometer experiment this experiment standing alone cannot serve as proof for Einstein's hypothesis.

*Einstein said that no number of experiments, however large, could prove him right but that a single experiment could prove him wrong.* —D. Halliday & R. Resnick<sup>37</sup>

There have been three important historical experiments. One supports Einstein, one has been corrupted, and one contradicts Einstein. The vacuum-mode experiment is consistent with Einstein's hypothesis —but does not prove its validity. The 1887 Michelson-Morley experiment, when misinterpreted as a “null result” as the historical record has done, is also consistent with Einstein's hypothesis —but cannot, in any way, support its validity. The gas-mode interferometer experiment, however, exposes the limitation of Einstein's hypothesis.

Dayton Miller performed that experiment whose results could not be explained by Einstein's theory (some would say the results proved Einstein wrong). In fact he repeated the experiment many times during the 1920s. He consistently found positive results; he consistently showed that the speed of light was *not* the same for all paths. Those were the aether experiments that Einstein feared.<sup>38</sup> They showed that his hypothesis was strictly limited in its applicability to the real world

Over the past 100 years or so there have been 8 well documented experiments that show positive results that the speed of light is anisotropic —the speed differs unequivocally for different paths!

In 1960 Professors David Halliday and Robert Resnick authored what became a highly popular physics textbook, from which the above two quotations were taken. As part of the discussion on light propagation and Einstein's hypothesis they wrote:

*The “single experiment” that might prove Einstein wrong has never been found.*<sup>39</sup>

That statement is notably absent in their 1997 revised edition, titled *Fundamentals of Physics Extended*.<sup>40</sup> Unfortunately Miller's experiments were not discussed and Einstein's hypothesis was still considered unconditionally valid.

From our present perspective, Einstein's hypothesis may still be considered valid, but only within the restricted domain of *symmetrical* relativity.

#### 9-4 The Over-Extended Conclusion

When Michelson and Morley calculated the speed of the “aether wind” they assumed they were dealing with a non-interactive medium. Although their 19<sup>th</sup> century aether was understood to conduct light waves it did not have the theoretical ability to contract moving objects. Their calculations told them that they had detected an “aether wind” of only 5 to 7 km/s —considerably less than the 30 km/s they had expected and far less than the 206 km/s to 290 km/s they had detected according to the Extended theory.

It is a most unfortunate historical twist that the report of the 1887 experiment was interpreted as a null result. While it is true that the 19<sup>th</sup> century concept of aether was annulled, it is not true that the aether wind measurement was null. The two opposite but distinct conclusions were, in the course of time, lumped together into a single convenient phrase, “the Michelson and Morley null result.” The lumped conclusion made its way into the pages of popular science and even textbooks, thus gaining undeserved authoritative status. This single over-extended conclusion is the root of what is now gradually being recognized as probably the biggest blunder in the history of science.

#### 9-5 Acknowledgment

The focus of this paper is on the method of extending what is casually referred to as *Einstein's relativity*. But the term may imply more than it should; to consider it, or refer to it, as *his* relativity, in a possessive sense, is regrettably an historical injustice. Both Einstein's theory and the Extended theory are heavily dependent on the prior work of Hendrik Antoon Lorentz (1853-1928). It is ironic that the process of extending relativity entailed a return to a Lorentzian-type aether. What Einstein, long ago, had stripped away needed to be replaced. With the exception of its dynamic nature and other properties not directly related to uniform motion, the DSSU aether model is similar to the Lorentzian model.

C. Kittel<sup>41</sup> has pointed out that if only a single author is to be recognized for the development of relativity, it is Lorentz who should be credited. Kittel also refers to others who played essential supporting roles, including Larmor, Fitzgerald and Voigt, to name a few.

The author wishes to acknowledge the great pioneering efforts and formidable achievements of H.A. Lorentz and encourage the reader to seek out his original works. Suggested selections include [42, 43, 44, 45, 46, 47].

## Appendix I. Derivation of the Extended Transformation Equations

Starting with the basic Lorentz transformations (from Table V) for converting the coordinates of system- $S$  to system- $S''$ ; specifically, we start with the equations for converting the  $x$ -axis coordinate and the clock time,

$$x'' = \gamma(x - vt), \quad (\text{A1})$$

$$t'' = \gamma\left(t - vx/c^2\right). \quad (\text{A2})$$

Figure A1 illustrates a typical situation of relative motion within the context of Einstein's special relativity. The velocity  $v$  is considered to be relative; that is, it does not matter which system is designated as the moving one.

However, within the context of an aether theory  $v$  acquires an absolute magnitude. We transition to the absolute expressions by fixing one of the systems to the rest-frame of the aether and by replacing  $v$  with  $v_B$ . The subscript "B" stands for the absolute moving-frame  $B$ , which is labeled in the following figures as  $S''$ . The relabeled Lorentz equations are,

$$x'' = \gamma_B(x - v_B t), \quad (\text{A3})$$

$$t'' = \gamma_B\left(t - v_B x/c^2\right), \quad (\text{A4})$$

where the Lorentz factor  $\gamma_B$  is subscripted because it contains the aether-referenced velocity  $v_B$ .

Figure A2 shows system  $S''$  moving in the *positive* direction with velocity  $v_B$  through aether-space.

Similarly, the Lorentz equations can be applied to the systems shown in Fig. A3. In the upper portion of the diagram they are treated as conventional relative systems for which

$$x = \gamma(x' - vt'), \quad (\text{A5})$$

$$t = \gamma\left(t' - vx'/c^2\right). \quad (\text{A6})$$

We are justified in applying the Lorentz transformations in this manner, since they are not concerned as to which system is actually in motion. Only the relative motion need be considered.

In the lower portion of the diagram, however, they are treated as *absolute* systems (one is absolutely stationary wrt aether, the other is moving wrt aether) for which

$$x = \gamma_A(x' - v_A t'), \quad (\text{A7})$$

$$t = \gamma_A\left(t' - v_A x'/c^2\right). \quad (\text{A8})$$

By combining the two sets of Lorentz equations above —by substituting (A7) & (A8) into (A3) & (A4)— we obtain the equations which directly relate the coordinates of independently moving systems  $S(\text{prime})$  and  $S(\text{double prime})$ . The result is the extended relativity equations shown in Table V,

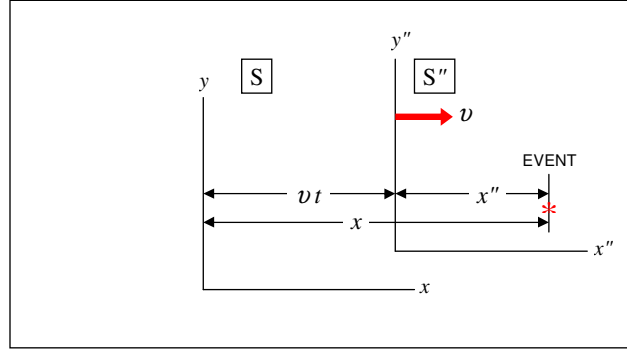

Fig. A1. Situation of inertial *relative* motion between reference frames  $S$  and  $S''$  to which the basic Lorentz equations are applied.

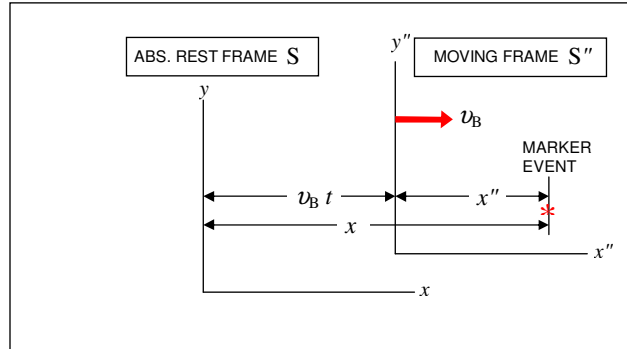

Fig. A2. Inertial reference frame  $S''$  has absolute velocity  $v_B$  relative to the absolute rest frame  $S$ .

$$x'' = \gamma_A \gamma_B [x' (1 + v_A v_B / c^2) - t' (v_A + v_B)] \quad (\text{A9})$$

$$t'' = \gamma_A \gamma_B [t' (1 + v_A v_B / c^2) - x' (v_A + v_B) / c^2]. \quad (\text{A10})$$

Which means, an observer in the moving Frame A (or  $S'$ ) is able to calculate  $x''$  and  $t''$  coordinates of some event that occurred in moving Frame B (or  $S''$ ) by using measurements  $x'$  and  $t'$  obtained from A's own frame. (Observer A determines his own speed  $v_A$  by directly measuring absolute motion with respect to aether-space; and determines  $v_B$  by direct communications or applying the DSSU Doppler formula.<sup>48</sup>)

By solving for  $x'$  and  $t'$  in equations (A9) and (A10), one obtains the corresponding transformations from  $S''$  to  $S'$  :

$$x' = \gamma_A \gamma_B [x'' (1 + v_A v_B / c^2) + t'' (v_A + v_B)] \quad (\text{A11})$$

$$t' = \gamma_A \gamma_B [t'' (1 + v_A v_B / c^2) + x'' (v_A + v_B) / c^2]. \quad (\text{A12})$$

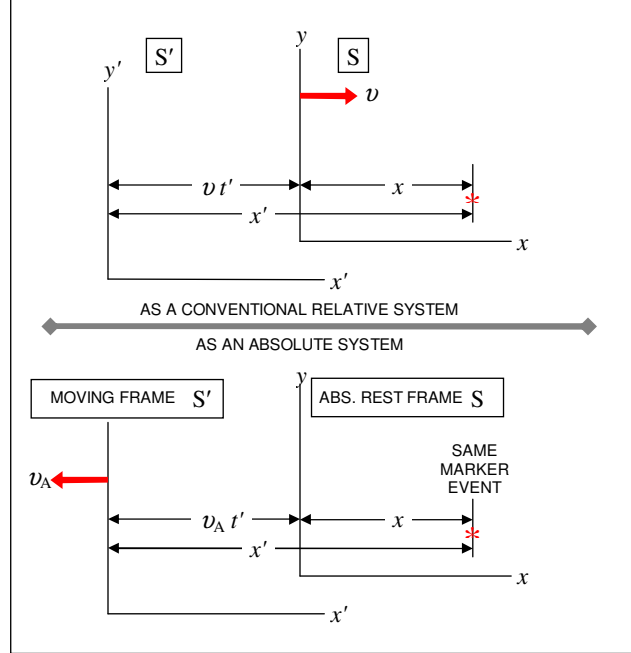

**Fig. A3.** Inertial reference systems  $S'$  and  $S$  are treated in accordance with Einstein's relativity (top) and DSSU extended relativity (bottom). The *relative* rightward motion  $v$  (top) is equivalent to the *absolute* leftward motion  $v_A$  (bottom). The Lorentz transformations apply to both interpretations.

## Appendix II. Derivation of the Apparent Velocity in Terms of Aether-Referenced Velocities

Suppose that the two systems shown in Fig. A4 move apart by a distance  $\Delta x'$  in a time interval of  $\Delta t'$ . Observer A notes that at time  $t'_1$  the position of point "B" projected onto the horizontal axis is  $x'_1$ . A brief time later observer A records that at time  $t'_2$  point "B" (projected onto the same axis) is now positioned at  $x'_2$ .

Using equations (A11) & (A12) we then obtain:

$$\Delta x' = x'_2 - x'_1$$

$$\Delta x' = \gamma_A \gamma_B \left[ \Delta x'' \left( 1 + \frac{v_A v_B}{c^2} \right) + \Delta t'' (v_A + v_B) \right] \quad (\text{A13})$$

and

$$\Delta t' = t'_2 - t'_1$$

$$\Delta t' = \gamma_A \gamma_B \left[ \Delta t'' \left( 1 + \frac{v_A v_B}{c^2} \right) + \Delta x'' (v_A + v_B) / c^2 \right]. \quad (\text{A14})$$

And by a simple division of the two equations we have,

$$\frac{\Delta x'}{\Delta t'} = \frac{\gamma_A \gamma_B \left[ \Delta x'' \left( 1 + \frac{v_A v_B}{c^2} \right) + \Delta t'' (v_A + v_B) \right]}{\gamma_A \gamma_B \left[ \Delta t'' \left( 1 + \frac{v_A v_B}{c^2} \right) + \Delta x'' (v_A + v_B) / c^2 \right]}. \quad (\text{A15})$$

Then, by dividing the numerator and denominator by  $\Delta t''$ ,

$$\frac{\Delta x'}{\Delta t'} = \frac{(\Delta x''/\Delta t'')(1 + v_A v_B/c^2) + (v_A + v_B)}{(1 + v_A v_B/c^2) + (\Delta x''/\Delta t'')(v_A + v_B)/c^2}. \quad (\text{A16})$$

Recall, the chosen moving point is “B”. Its change in position within system  $S''$  is represented by  $\Delta x''$ . But “B” is nonmoving in its own frame, meaning  $\Delta x'' = 0$ , and consequently,  $(\Delta x''/\Delta t'') = 0$ .

What about  $(\Delta x'/\Delta t')$ ? In the differential limit, it represents the apparent velocity of the chosen point; it represents the relative velocity that observer A determines for point “B” —a point that essentially represents the  $S''$  system. By making these substitutions, eqn (A16) becomes

$$v_{\text{relative}} = \frac{v_A + v_B}{1 + (v_A v_B/c^2)}. \quad (\text{A17})$$

Note 1. The left-hand side of the expression symbolizes the **apparent** motion. But on the right-hand side, the velocities  $v_A$  and  $v_B$  are aether-referenced motion. Each velocity  $v_A$ ,  $v_B$ , and  $v_C$ , etc., is intrinsic to a particular reference-system or object; and is independent of external observers regardless of their uniform motion.

Note 2. Because of the symmetry of the situation, eqn (A17) also applies to observer B's perception of A's relative motion.

Note 3. The equation can be used to convert any relative velocity into corresponding aether-referenced velocities. Most importantly, it can be used to “extend” any ESR equation into a *DSSU extended relativity equation*.

The derived equation serves as the *extended relativity conversion expression*:

$$v = \frac{v_A + v_B}{1 + (v_A v_B/c^2)} \quad (\text{A18})$$

### Appendix III. Sign Rule for Extended Relativity Equations

**A sign rule is required for independent absolute (aether-referenced) motion.** Any velocity (or velocity component) referenced to the aether medium follows the simple sign convention: Use **positive** sign when *absolute velocity* is away from the other frame of reference. Use **negative** sign when *absolute velocity* is towards the other frame. This, of course, means that the instant two frames cross paths, the signs change.

\* \* \* \*

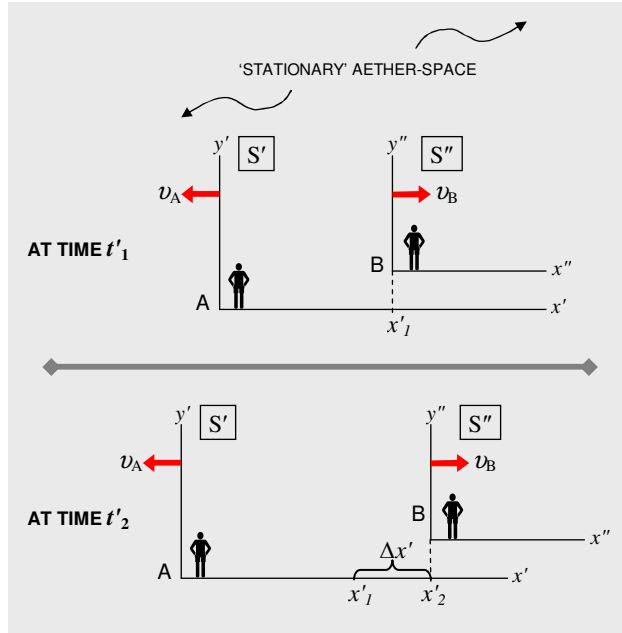

**Fig. A4.** Two inertial reference frames each having independent absolute motion. Observer A measures the position of point B at two different times. The goal is to determine the *apparent* velocity of separation.

## REFERENCES

- <sup>1</sup> Ranzan, C. *Why Einstein did not receive the Nobel Prize for his theory of relativity*, Phys. Essays Vol. **22**, 564 (2009), DOI:10.4006/1.3252983
- <sup>2</sup> As quoted in: DeMeo, James. 2002. *Dayton Miller's Ether-Drift Experiments: A Fresh Look*. (Posted on [www.orgonelab.org/miller.htm](http://www.orgonelab.org/miller.htm))
- <sup>3</sup> Pais, Abraham. 1982. *Subtle Is the Lord: The Science and the Life of Albert Einstein*. (Oxford University Press, New York) p467
- <sup>4</sup> Einstein, A. *Relativity The Special and the General Theory* (1961, Wings Books, New York) p59
- <sup>5</sup> Ibid. p55
- <sup>6</sup> Ibid. p55
- <sup>7</sup> Ibid.
- <sup>8</sup> Joos, G. *Ann. der Physik*, 1930, Bd. **7**, 385
- <sup>9</sup> Kennedy, H.P and Thorndike, E.M., *Rev. Mod. Phys.* **42** 400 (1932)
- <sup>10</sup> A. Brilliet and J.L. Hall, **Phys. Rev. Lett.** **42**, No.9, pp549-552(1979)
- <sup>11</sup> C. Braxmaier, H. Müller, O. Pradl, J. Mlynek, A. Peters and S. Schiller, **Phys. Rev. Lett.** **88**, 010401(2002)
- <sup>12</sup> Müller, H. *et al. Modern Michelson-Morley experiment using cryogenic optical resonators.* **Phys. Rev. Lett.**, 2003, v. 91(2), 020401-1
- <sup>13</sup> Michelson, Albert A. and Morley, Edward W. 1887. *On the Relative Motion of the Earth and the Luminiferous Ether* (The American Journal of Science, Vol 34 No. 203)
- <sup>14</sup> Miller, Dayton C. *The Ether-Drift Experiment and the Determination of the Absolute Motion of the Earth.* **Reviews of Modern Physics**, Vol. 5 July, 1933, p234
- <sup>15</sup> Ibid., p222
- <sup>16</sup> Stewart, Albert B. *The Discovery of Stellar Aberration* (Scientific American, Mar 1964) p107
- <sup>17</sup> *Physics, Part II*, David Halliday, Robert Resnick (John Wiley & Sons, Inc., New York, 1960, 1962) p999 & 1001
- <sup>18</sup> Stewart, Albert B. *The Discovery of Stellar Aberration* (Scientific American, Mar 1964) p100
- <sup>19</sup> Ibid., p108
- <sup>20</sup> Cahill, R.T. *A New Light-Speed Anisotropy Experiment: Absolute Motion and Gravitational Waves Detected* (**Progress in Physics**, October, 2006 Vol. 4) p88
- <sup>21</sup> Cahill, R.T. *The Roland De Witte 1991 Experiment (to the Memory of Roland De Witte)* (**Progress in Physics**, Vol. 3, July, 2006 ) pp60-65 [Posted at: [www.ptep-online.com/index\\_files/2006/PP-06-11.PDF](http://www.ptep-online.com/index_files/2006/PP-06-11.PDF) ]
- <sup>22</sup> Cahill, R.T. *A New Light-Speed Anisotropy Experiment: Absolute Motion and Gravitational Waves Detected* (**Progress in Physics**, October, 2006 Vol. 4)
- <sup>23</sup> Ranzan, C. 2009. *DSSU Relativity --The Lorentz Transformations Applied to Aether-Space*, **Physics Essays** Vol **23**, No.3, p520 (2010 Sept)
- <sup>24</sup> Hesse, M.B. 1961. *Forces and Fields* (Littlefield, Adams & Co., Totown, New Jersey, 1965) P231
- <sup>25</sup> Ibid.
- <sup>26</sup> Gift, S.J.G. *One-Way Light Speed Measurement Using the Synchronized Clocks of the Global Positioning System (GPS)*, **Physics Essays**, Vol.**23**, No2, pp 271-275, June 2010
- <sup>27</sup> Gift, S.J.G. *Light Speed Invariance is a Remarkable Illusion*, **Physics Essays**, **23**, 1, 2010
- <sup>28</sup> Sato, M. *The Velocity of Electromagnetic Wave is Observed Differently Depending on the Observer's Velocity*, **Physics Essays**, **23**, 405, 2010
- <sup>29</sup> Ranzan, C. *Contradiction Divides Two Aether Theories*, **Physics Essays** Vol **24**, No.3, p419 (2011 Sept)
- <sup>30</sup> Gift, S.J.G. *Light Speed Invariance is a Remarkable Illusion*, **Physics Essays**, **23**, 1, 2010
- <sup>31</sup> Gift, S.J.G. *One-Way Light Speed Measurement Using the Synchronized Clocks of the Global Positioning System (GPS)*, **Physics Essays**, Vol.**23**, No2, pp 271-275, June 2010
- <sup>32</sup> Selleri, F. *Noninvariant one-way velocity of light*, *Found. Phys* **26**, 641-664, 1996
- <sup>33</sup> Lévy, Joseph, *From Galileo to Lorentz... and Beyond –Principles of a Fundamental Theory of Space and Time* (Published by C. Roy Keys Inc., Montreal, Canada, 2003)
- <sup>34</sup> Selleri, F. *Recovering the Lorentz Ether*, **Apeiron**, **11**, 246 (2004)
- <sup>35</sup> *Physics, Part II*, David Halliday, Robert Resnick (John Wiley & Sons, Inc., New York, 1960, 1962) p1094
- <sup>36</sup> Ibid.

- 
- <sup>37</sup> Ibid.
- <sup>38</sup> Ranzan, C. *Why Einstein did not receive the Nobel Prize for his theory of relativity*, Phys. Essays 22, 564 (2009), DOI:10.4006/1.3252983
- <sup>39</sup> *Physics, Part II*, David Halliday, Robert Resnick (John Wiley & Sons, Inc., New York, 1960, 1962) p1094
- <sup>40</sup> *Fundamentals of Physics Extended*, 5th Edition, David Halliday, Robert Resnick, Jearl Walker (John Wiley & Sons, Inc., New York, 1997) p927
- <sup>41</sup> Kittel, C. *Larmor and the Prehistory of the Lorentz Transformations*, Am. J. Phys. 42 726 (Sept 1974)
- <sup>42</sup> Lorentz, H.A. (1895), *Versuch einer theorie der electrischen und optischen erscheinungen in bewegten Körpern*, Leiden: E.J. Brill
- <sup>43</sup> Lorentz, H.A. (1899) "Simplified Theory of Electrical and Optical Phenomena in Moving Systems", *Proceedings of the Royal Netherlands Academy of Arts and Sciences* **1**: 427–442
- <sup>44</sup> Lorentz, H.A. (1904) "Electromagnetic phenomena in a system moving with any velocity smaller than that of light", *Proceedings of the Royal Netherlands Academy of Arts and Sciences* **6**: 809–831
- <sup>45</sup> Lorentz, H.A. (1910/1931) *Lecture on theoretical physics, Vol.3*, (MacMillan,London)
- <sup>46</sup> Lorentz, H.A. (1916) [The theory of electrons](http://www.archive.org/details/electronstheory00lorerich), (B.G. Teubner, Leipzig & Berlin)
- <sup>47</sup> Lorentz, H.A. (1928) "[Conference on the Michelson-Morley Experiment](#)", *The Astrophysical Journal* **68**: 345–351
- <sup>48</sup> Ranzan, C. (2009) *Resolving a Paradox in Special Relativity —Absolute Motion and the Unified Doppler Equation*. Physics Essays Vol **23**, p594 (2010 Dec)